

Shark

POWERDETECT

**Upright Vacuum with DuoClean,
Detect Technology, Powered Lift
Away, Anti Hair Wrap Plus, and
Anti-Odour Technology**

AZ3900 Series

OWNER'S GUIDE



THANK YOU

for purchasing the Shark POWERDETECT Upright Vacuum with DuoClean, Detect Technology, Powered Lift Away, Anti Hair Wrap Plus and Anti-Odour Technology



TIP: You can find the model and serial numbers on the QR code label on the bottom of the back of the vacuum pod.

REGISTER YOUR PURCHASE

TO BENEFIT FROM YOUR PRODUCT'S EXTENDED GUARANTEE, SIMPLY REGISTER YOUR PURCHASE AT:

- sharkclean.co.uk/register-guarantee
- 0800 862 0453
- Scan QR code using mobile device

Please note, products purchased directly from Shark® are automatically registered.

Benefits of registering your product and creating an account:

- Get easier, faster product support and access to guarantee information
- Access troubleshooting and product care instructions
- Be among the first to know about exclusive product promotions

RECORD THIS INFORMATION

Model Number: _____

Serial Number _____

Date Code: _____

Date of Purchase (Keep receipt): _____

Store of Purchase: _____

TECHNICAL SPECIFICATIONS

Voltage: 220-240V~, 50-60Hz

Watts: 600W

ODOUR NEUTRALISER TECHNOLOGY SPECIFICATIONS

1. Product Name:
Anti-Odour Technology Cartridge
2. Weight: 17.6g / 0.62oz
3. Ingredients: Solid SM composite polymer C17 + fragrance SE 272235

PLEASE READ CAREFULLY AND KEEP FOR FUTURE REFERENCE.

This instruction manual is designed to help you get a complete understanding of your new Shark Power Detect Upright Vacuum with DuoClean, Powered Lift Away, Self-Cleaning Brushroll and Anti-Odour Technology.

If you have any questions, please call the customer service line on 0800 862 0453.



CONTENTS

Important Safety Instructions	4
Getting to know your Shark Lift Away	6
Assembly	8
Power cord	9
Anti Odour Technology	10
Settings	12
Detect Indicators	13
Cleaning modes	14
Emptying the Dust cup	15
Replacing the Filters	16
Cleaning the brush roll	17
Sensor Maintenance	18
checking for blockages	19
Available Accessories	20
Trouble shooting	21
Guarantee	22



This marking indicates that this product should not be disposed of with other household wastes throughout the UK. To prevent possible harm to the environment or human health from uncontrolled waste disposal, recycle it responsibly to promote the sustainable reuse of material sources. To return your used device, please use the return and collection systems or contact the retailer where this product was purchased. They can take this product for environmentally safe recycling.

IMPORTANT SAFETY INSTRUCTIONS

FOR HOUSEHOLD USE ONLY • PLEASE READ ALL INSTRUCTIONS BEFORE USING THIS VACUUM.

IF YOU HAVE DELICATE OR WOOL CARPETS, PARTICULARLY LOOP PILE, PLEASE TRY THE VACUUM ON A HIDDEN AREA FIRST TO ENSURE THE SPINNING BRUSH-ROLLS DO NOT DAMAGE OR UNPICK CARPET FIBRES.

⚠ WARNING

REDUCE THE RISK OF FIRE, ELECTRIC SHOCK, INJURY, OR PROPERTY DAMAGE:

⚠ WARNING: Children should be supervised to ensure that they do not play with this vacuum cleaner.

GENERAL WARNINGS

- 1 Inspect power cord and plug for any damage before use. **DO NOT** use vacuum cleaner with a damaged cord or plug. Turn off all controls before plugging in or unplugging the vacuum cleaner. Store your vacuum cleaner with the power cord secured around the two cord hooks. To minimise the risk of power cord damage, do not allow the motorised brush-roll to ingest the cord. If this occurs, immediately shut off power to the vacuum and remove the cord.
- 2 Your vacuum cleaner consists of a motorised floorhead, wand, hose, and/or vacuum pod. This device contains electrical connections, electrical wiring, and moving parts that potentially present risk to the user.
- 3 Use only identical replacement parts.
- 4 Carefully observe and follow the instructions provided below to avoid improper use of the vacuum cleaner. **DO NOT** use the vacuum for any purpose other than those described in this manual.
- 5 Before use, carefully inspect all parts for any damage. **DO NOT** use if any parts are damaged.
- 6 The use of an extension cord is **NOT** recommended.
- 7 **CAUTION:** This vacuum cleaner contains electrical connections and no serviceable parts.

USE WARNINGS

- 8 This vacuum cleaner can be used by persons with reduced physical, sensory or mental capabilities or lack of experience and knowledge if they have been given supervision or instruction concerning use of the vacuum cleaner in a safe way and understand the hazards involved.

- 9 **Do not allow the vacuum cleaner to be used by children.** Keep the vacuum cleaner and its cord out of reach of children. Do not allow to be used as a toy. Close supervision is necessary when used near children.

CLEANING AND USE

- 10 Always turn off the vacuum cleaner before connecting or disconnecting any motorised floorheads or other accessories.
- 11 **DO NOT** handle plug or vacuum cleaner with wet hands.
- 12 **DO NOT** use without filters in place.
- 13 Only use Shark® branded filters and accessories. Damage caused by the use of non-Shark® parts may not be covered by your guarantee.
- 14 **DO NOT** damage the power cord:
 - a) **DO NOT** pull or carry vacuum cleaner by the cord or use the cord as a handle.
 - b) **DO NOT** unplug by pulling on cord. Grasp the plug, not the cord.
 - c) **DO NOT** run the vacuum cleaner over the power cord, close a door on the cord, pull the cord around sharp corners, or leave the cord near heated surfaces.
- 15 **DO NOT** put any objects into floorhead or accessory openings. **DO NOT** use with any opening blocked; keep free of dust, lint, hair, and anything that may reduce airflow.
- 16 **DO NOT** use if floorhead or accessory airflow is restricted. If the air paths or the motorised floor floorhead become blocked, turn the vacuum cleaner off and unplug from electrical socket. Remove all obstructions before you plug in and turn on the unit again.
- 17 Keep floorhead and all vacuum openings away from hair, face, fingers, uncovered feet, or loose clothing.
- 18 **DO NOT** use if vacuum cleaner is not working as it should, or has been dropped, damaged, left outdoors, or dropped into water.

SAVE THESE INSTRUCTIONS

READ ALL INSTRUCTIONS BEFORE USE

- 19 If the supply cord is damaged, it must be replaced by the manufacturer, its service agent or similar qualified persons in order to avoid a hazard.
- 20 Use extra care when cleaning on stairs.
- 21 **DO NOT** leave the vacuum cleaner unattended while plugged in.
- 22 When powered on, keep the vacuum cleaner in motion over the carpet surface at all times to avoid damaging the carpet fibres.
- 23 **DO NOT** place vacuum cleaner on unstable surfaces such as chairs or tables.
- 24 **DO NOT** use to pick up:
 - a) Liquids
 - b) Large objects
 - c) Hard or sharp objects (glass, nails, screws, or coins)
 - d) Large quantities of dust (drywall dust, fireplace ash, or embers). **DO NOT** use as an attachment to power tools for dust collection.
 - e) Smoking or burning objects (hot coals, cigarette butts, or matches)
 - f) Flammable or combustible materials (lighter fluid, petrol, or kerosene)
 - g) Toxic materials (chlorine bleach, ammonia, or drain cleaner)
- 25 **DO NOT** use in the following areas:
 - a) Poorly lit areas
 - b) Wet or damp surfaces
 - c) Outdoor areas
 - d) Spaces that are enclosed and may contain explosive or toxic fumes or vapours (lighter fluid, petrol, kerosene, paint, paint thinners, mothproofing substances, or flammable dust)
- 26 Turn off all controls before plugging in or unplugging the vacuum.
- 27 Unplug from electrical socket when not in use and before any maintenance or cleaning.
- 28 To clean: wipe down the unit with water only. Washing with cleaning chemicals could damage the unit.
- 29 During cleaning or routine maintenance, **DO NOT** cut anything other than hair, fibres, or string wrapped around the brush-roll.
- 30 Allow all filters to air-dry completely before replacing in the vacuum to prevent liquid from being drawn into electrical parts.
- 31 Make sure the dust cup and all filters are in place after routine maintenance.
- 32 Secure the power cord around the two cord hooks during storage.
- 33 Observe the following when interacting with the Anti-Odour Technology cartridge:
 - a) **DO NOT** attempt to disassemble Anti-Odour Technology cartridge.
 - b) Avoid direct contact with the fragrance pod in the cartridge.
 - c) **DO NOT** directly inhale from the Anti-Odour Technology cartridge.
 - d) Keep away from children and pets.
 - e) Keep away from heat, sparks and open fires.
 - f) **DO NOT** place in direct sunlight.

FRAGRANCE CARTRIDGE FIRST AID

- a) Avoid contact with fabrics and finished surfaces.
- b) Eye contact: Remove contact lenses if present. Rinse continuously with water for several minutes.
- c) Skin contact: Wash hands thoroughly after handling. If irritation or rash develops, seek medical advice/attention.
- d) Inhalation: Move person to fresh air if they are experiencing any respiratory symptoms. If symptoms persist, seek medical advice/attention.
- e) Ingestion: **DO NOT** induce vomiting. Seek medical advice/attention

ANTI-ODOUR TECHNOLOGY WARNING



May cause an allergic reaction to skin if in direct contact with contents of cartridge. Wear protective gloves if directly coming into the contact with the cartridge material, wash skin thoroughly after handling. Harmful if swallowed. Avoid breathing in mist or vapours, intentional misuse and directly inhaling contents may be dangerous. Avoid release to the environment. Very toxic to aquatic life with long lasting effects, ensure cartridge is disposed of correctly as general waste.

GETTING TO KNOW YOUR SHARK POWER DETECT UPRIGHT VACUUM WITH DUOCLEAN, DETECT TECHNOLOGY, POWERED LIFTAWAY, ANTI HAIR WRAP PLUS, AND ANTI-ODOUR TECHNOLOGY

WELCOME!

Congratulations on your purchase. Use this instruction manual to learn about your new vacuum's great features. From assembly to use to maintenance, you will find it all in here.

MAIN UNIT

- A** Power Button
- B** Handle Release Button
- C** Surface Selector
- D** Hose
- E** Upper Cord Hook
- F** Powered Lift-Away Button
- G** Wand Release Button
- H** Lift-Away Pod
- I** Dust Cup Release Button
- J** Wand
- K** Lower Cord Hook
- L** Filter Door
- M** Motorised Floorhead
- N** Anti-Odour Technology Dial
- O** Brush-Roll Garage
- P** Headlights
- Q** Anti-Hair Wrap Plus Brush-Roll
- R** Brush-Roll Release
- S** Soft Roller

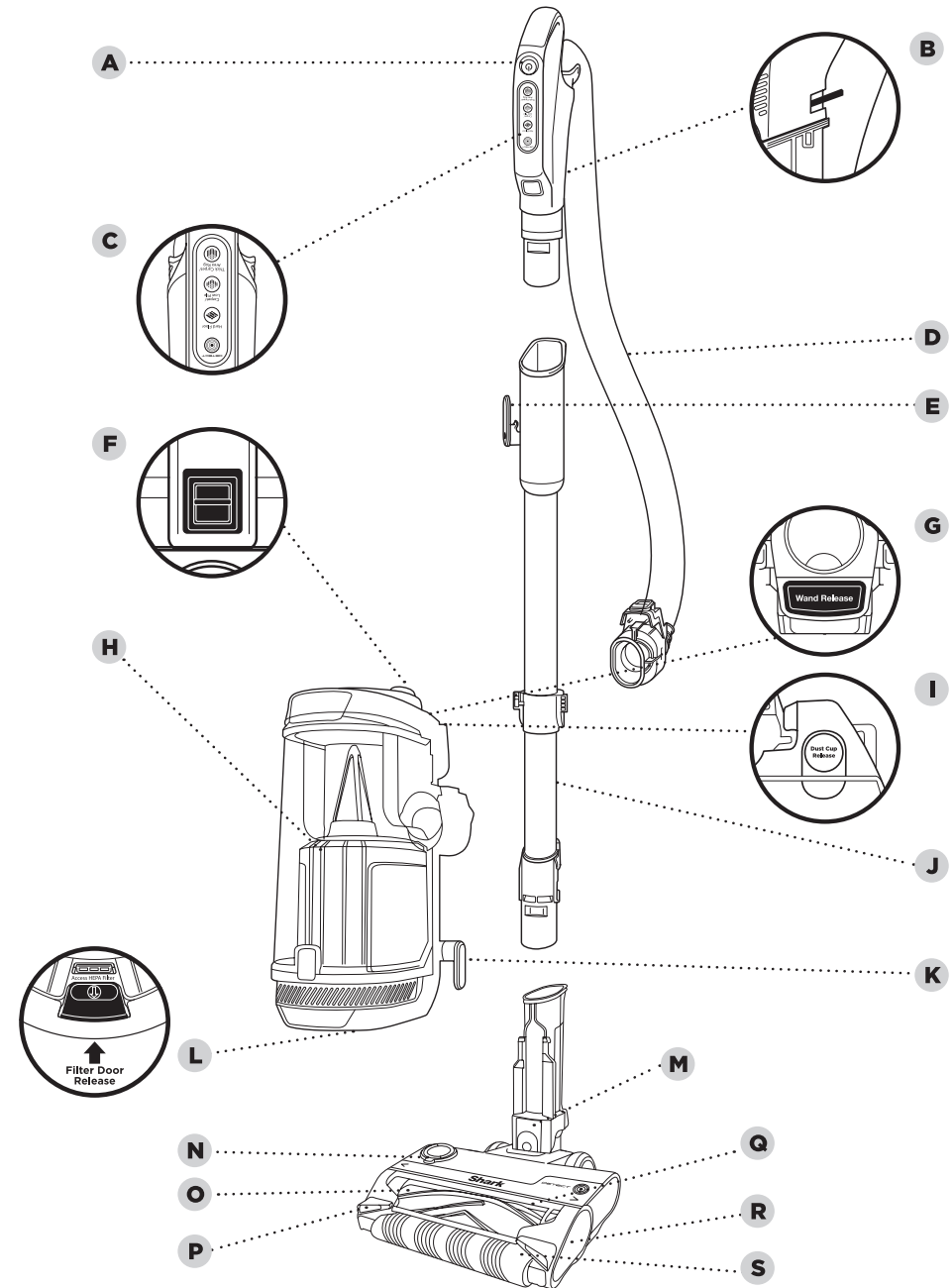

NOTE: The dust cup has to be removed to see the filter access button.

ASSEMBLY

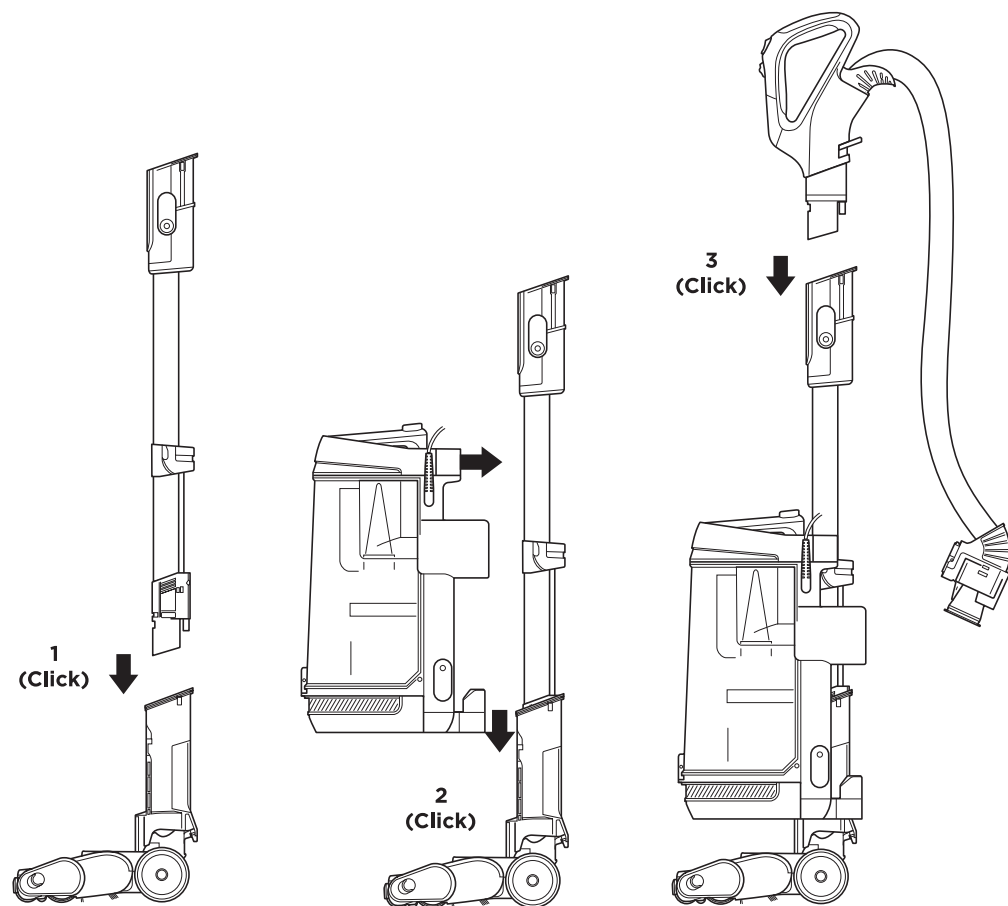

1. Place motorized **Nozzle** on floor and insert **Wand**, pressing it in until it clicks securely into place.
2. Place **Pod** onto wand and slide down to connect.
3. Insert **Handle** into wand, pressing it in until it clicks securely into place.
4. Connect **Hose** to back of pod, pressing it in until it clicks securely into place.
5. Store included accessories on the **Accessory Posts** on the pod.
6. Remove **Odour Neutraliser Technology Dial** from bag. Flip up the dial handle, align the teal arrows, then insert the dial into the nozzle.
7. To lock and engage the dial, rotate it counterclockwise until it clicks into the desired odour intensity setting.

See Odour Neutraliser Technology Settings and Odour Cartridge Replacement sections for more information and instructions.

IMPORTANT: For proper operation, ensure all connections are securely clicked into place.

ASSEMBLY

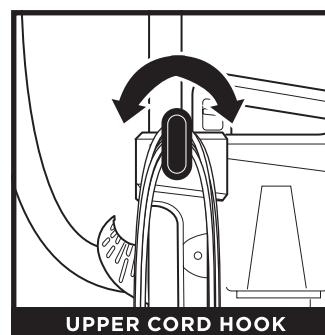
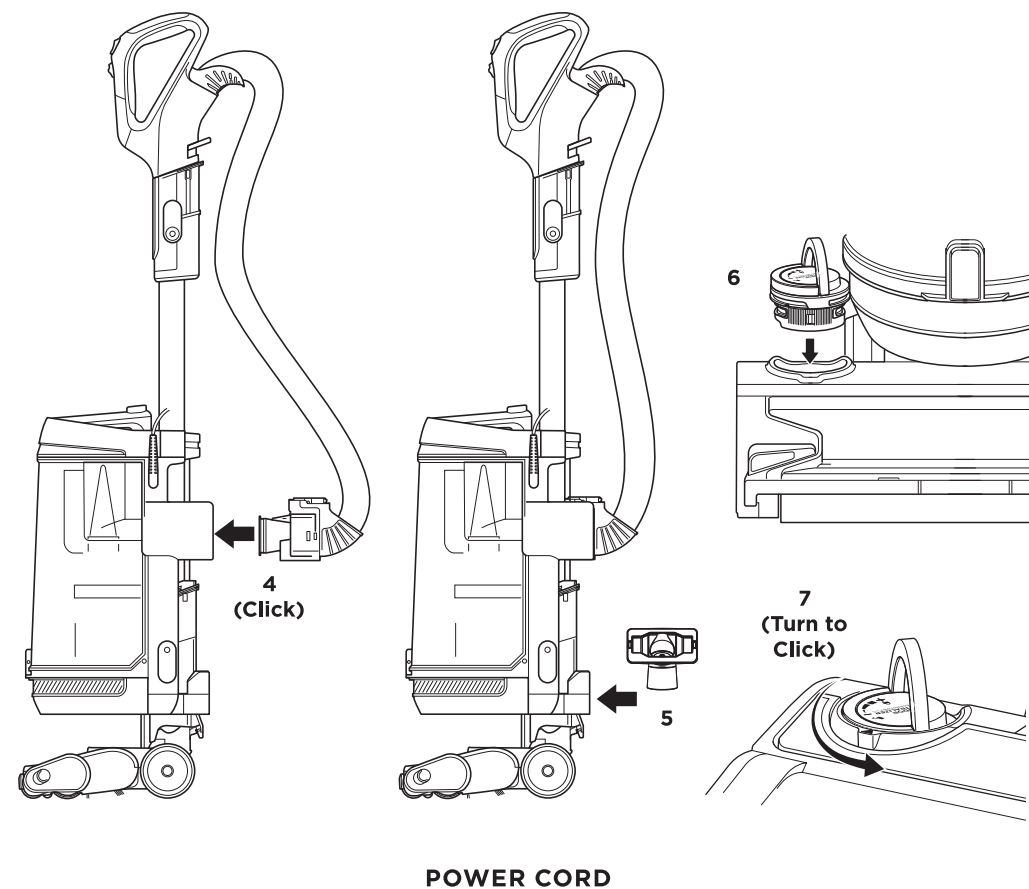

For cord access, rotate upper hook down and remove cord.

ANTI-ODOUR TECHNOLOGY



ODOUR DIAL

Flip up the dial handle and rotate the odour dial to adjust Odour Neutraliser Technology intensity or to unlock the dial for cartridge access.

Insertion/Removal: Rotate the odour dial to align the teal arrows. Remove the dial to access the odour cartridge for removal or replacement.

Low: Rotate the dial toward the Low position to decrease the intensity to the lowest level when the vacuum is in use.

High: Rotate the dial toward the High position for the highest intensity level when the vacuum is in use. This position is the recommended setting for optimal performance.

ANTI-ODOUR TECHNOLOGY TIPS

Odour Dial Must be Installed for Vacuum to Function Properly

- Remove odour cartridge from dial if you don't want the benefits of Odour Neutraliser Technology.

Maintenance Required

- Clean all filters as recommended under Cleaning Filters.
- Empty the dust cup before storing your vacuum.
- Replace the cartridge as recommended under odour cartridge replacement.
- Visit sharkclean.co.uk to learn more and purchase replacements.

Fragrance Strength Over Time

- The intensity of the Odour Neutraliser Technology's fragrance may diminish over time. It may also have no noticeable fragrance at all. This is natural and does not indicate the technology isn't working. Follow replacement instructions to ensure continued performance.

NOTES:

- The odour dial needs to be installed for the vacuum to function properly, with or without the odour cartridge.
- Anti-Odour Technology effectively deodorises while interacting with odours from inanimate sources.

ANTI-ODOUR TECHNOLOGY

ODOUR CARTRIDGE REPLACEMENT



1. REMOVE ODOUR DIAL FROM NOZZLE

Flip up the handle and rotate the dial clockwise until the two teal arrows are aligned. Pull the handle to remove the dial from the nozzle.

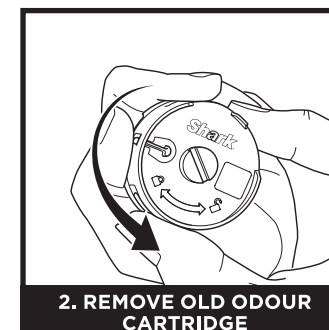

2. REMOVE OLD ODOUR CARTRIDGE

Rotate the cartridge counterclockwise in the dial housing and pull out the cartridge to remove it.

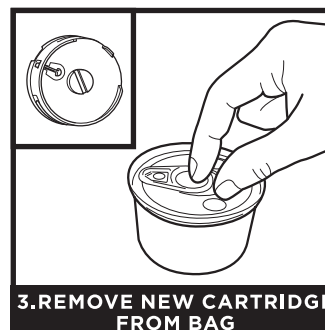

3. REMOVE NEW CARTRIDGE FROM BAG

Remove the new odour cartridge from the sealed packaging. To maintain the life of the cartridge, keep it in the sealed packaging until you are ready to install it.

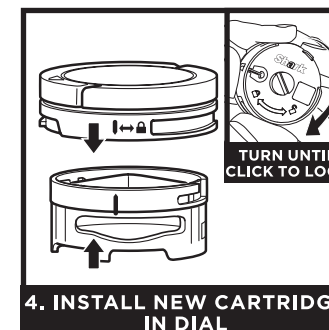

4. INSTALL NEW CARTRIDGE IN DIAL

Align the yellow arrow on the side of the cartridge with the yellow arrow on the side of the dial cover, then insert the cartridge into the dial. Rotate the cartridge clockwise to lock it in place.

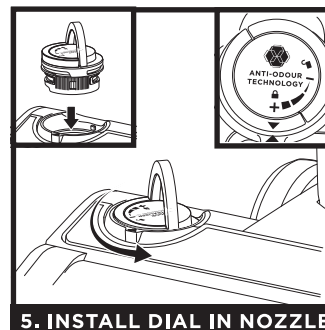

5. INSTALL DIAL IN NOZZLE

Align the teal arrow on the dial cover with the teal arrow on the nozzle, then reinsert the dial into the nozzle. Rotate the dial counterclockwise until it clicks into an intensity setting to engage. Rotate further to change the intensity setting.

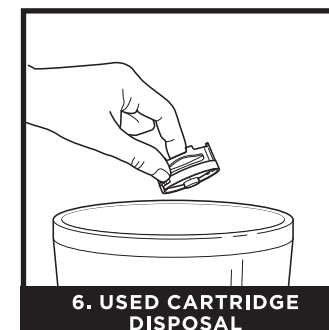

6. USED CARTRIDGE DISPOSAL

Dispose of the old cartridge by dropping it into the trash.

NOTE: Odour cartridges should be replaced every 6 months for optimal Anti-Odour Technology performance.

WHOLE-HOME CLEANING

SETTINGS

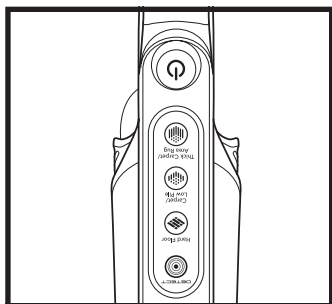

TOUCHSCREEN SELECTOR

To select the cleaning mode, tap one of the icons on the touchscreen on the handle:

 **Detect Mode:** Select Detect mode to activate Smart Detect technology. In this mode, the vacuum will automatically detect hidden dirt, different types of floor surfaces, and edges and corners, and will adjust suction to maximize cleaning performance.

Manual Surface Modes: Tap one of the surface modes to clean specific surfaces without Smart Detect Technology.

 **Hard Floor:** Suction and brushroll speed optimized for cleaning hard floor surfaces and above-floor areas.

 **Carpet/Low Pile:** Suction and brushroll speed optimized for deep cleaning low-pile carpets.

 **Thick Carpet/Area Rug:** Suction and brushroll speed optimized for cleaning thick carpets and area rugs.

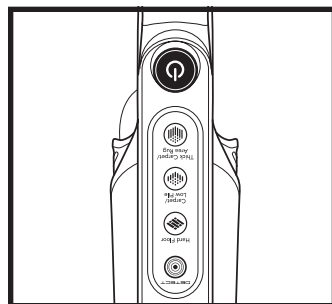

POWER BUTTON

Press power button to turn on vacuum. Please note the brushrolls will not spin unless the wand is reclined.

SMART DETECT TECHNOLOGY

FloorDetect: Senses different surface types and automatically adjusts brushroll speed and suction power for optimized cleaning on each surface.

DirtDetect: Senses hidden debris you can't see and automatically boosts suction power. The LED indicator light will turn purple, and suction will increase for more cleaning power. Continue cleaning until the light turns white, indicating the surface is cleaned.

EdgeDetect: Focuses and maximizes suction along corners and edges to target stubborn dirt. When an edge is detected, the arrow indicator on the top of the nozzle will turn on.

WHOLE-HOME CLEANING

DETECT INDICATORS

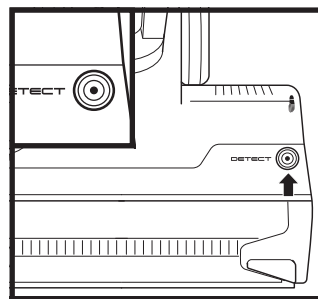

DIRTDETECT INDICATOR

 **DIRTDETECT INDICATOR**

White: Cleaning.

Purple: Cleaning Boost. Surface is dirty, suction will increase to pull in hidden debris.

Red: Sensors require cleaning. Reference maintenance section.

NOTE: Detect Indicators will be off in manual surface modes.

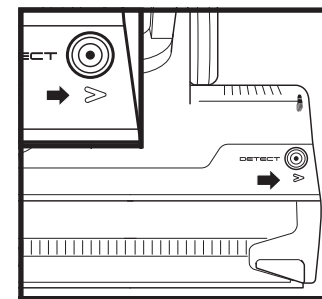

EDGEDETECT INDICATORS

 **EDGEDETECT INDICATORS**

When an edge is detected, the arrow indicator closest to edge will turn on, and the headlights closest to the edge will brighten to illuminate hidden debris.

Blinking White Arrows: When the EdgeDetect sensors are obstructed, the arrow indicator lights will blink. Move the unit away from the edge, turn off power, and restart. If the arrows continue to blink, clean the sensors.

HEADLIGHT INDICATOR LIGHTS

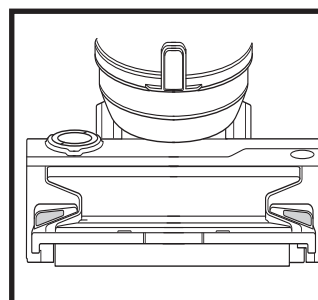

HEADLIGHTS

The headlights will flash or turn red to indicate issues that need attention.

Solid White Lights: The brushrolls are spinning and the unit is working as intended.

Solid Red Lights: There is a jam in the brushroll area. Turn off the vacuum and unplug it, then remove any blockages in the nozzle.

Flashing Red Lights: The motorized floor nozzle is overheating. Turn off the vacuum, unplug it, and remove any blockages. Let the vacuum cool down for at least 60 minutes before restarting.

Flashing White Lights: The vacuum is operating in an environment that is either too hot or too cold.

NOTE: For deep cleaning per ASTM F608 (embedded dirt in carpets), please set to **Carpet/Low Pile** mode.
NOTE: For maximum suction for above-floor cleaning per ASTM F558, set to **Hard Floor** mode.

WHOLE-HOME CLEANING

CLEANING MODES

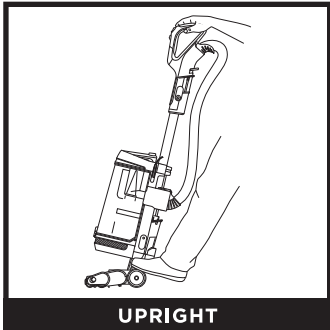

UPRIGHT

To engage brushrolls, step on floor nozzle and tilt handle back.

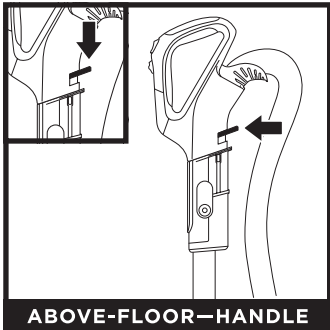

ABOVE-FLOOR—HANDLE

Press the **Handle Release** button to detach the handle from the wand.

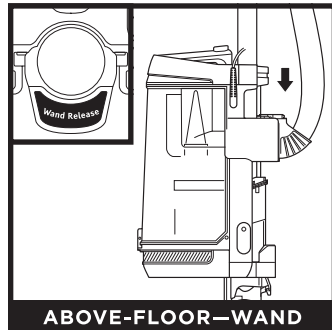

ABOVE-FLOOR—WAND

Press the **Wand Release** button to detach the wand from the pod.

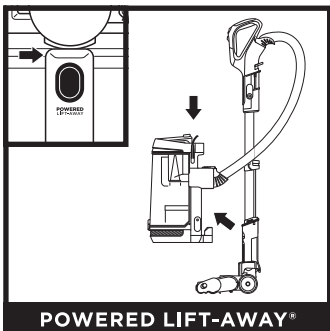

POWERED LIFT-AWAY®

Press the **Lift-Away** button to detach the pod from the floor nozzle.

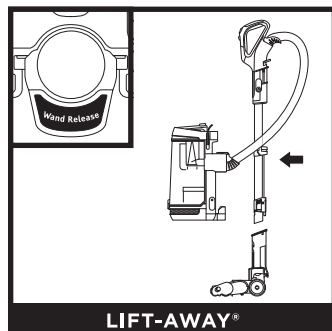

LIFT-AWAY®

With the pod removed, press the **Wand Release** button to detach the wand from the floor nozzle.

NOTE: All accessories are compatible with both the wand and the handle.

EMPTYING THE DUST CUP

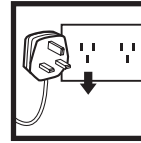

IMPORTANT: Unplug the power cord before performing any maintenance.

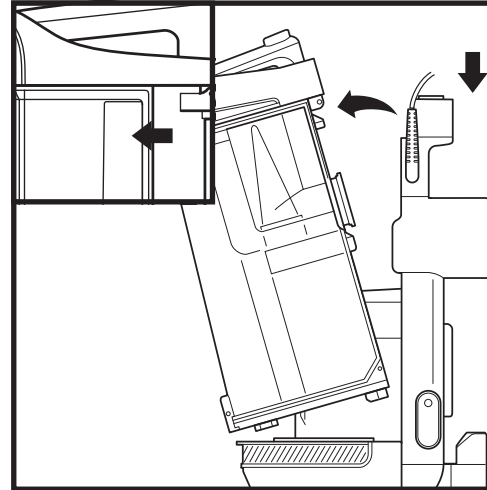

To remove **Dust Cup**, press release button on top of the pod. Tilt dust cup away from wand, then lift to remove.

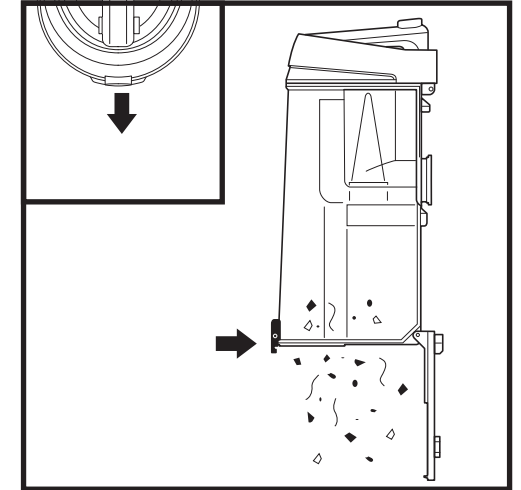

To empty debris into trash, press lower release button and bottom of dust cup will drop open.

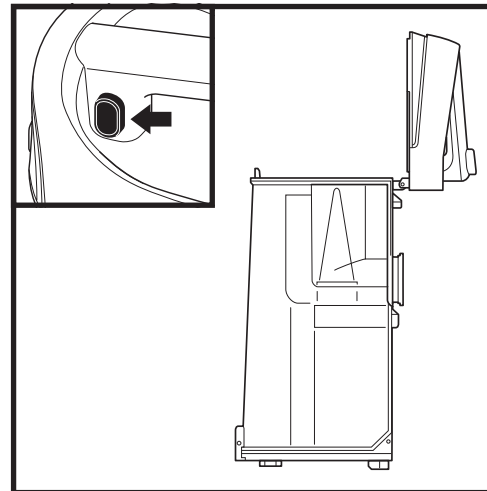

To remove collected debris from **Lint Screen**, press top release button and lift handle to access screen.

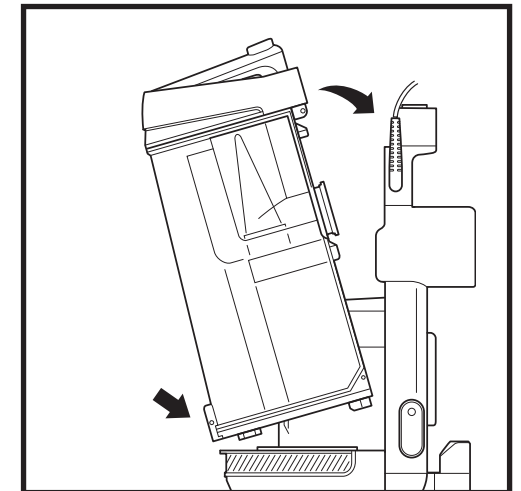

To reinstall, place bottom of dust cup into pod and then tilt until it clicks into place.

CLEANING AND REPLACING THE FILTERS

CLEANING FILTERS

Regularly rinse and replace the filters to maintain your vacuum's suction power.

To prevent damage from cleaning chemicals, rinse filters with cold water only. Allow all filters to air-dry for at least 24 hours before reinstalling them to prevent liquid from being drawn into electric parts.

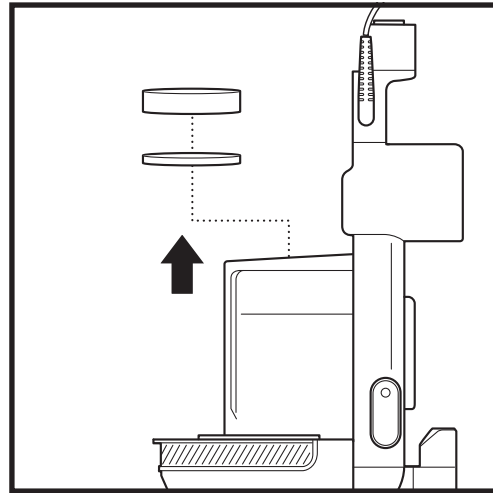

CLEAN PRE-MOTOR FILTERS EVERY MONTH

Remove **Dust Cup**, then lift out **Filters**.

IMPORTANT: DO NOT use soap when cleaning the filters.

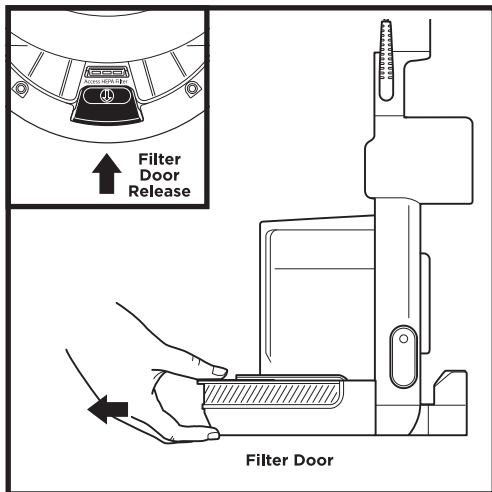

CLEAN POST MOTOR FILTER EVERY YEAR

With the dust cup removed, press the release button on the **Filter Door**. Pull the door forward, slide it out, then remove the **Post Motor Filter**.

To reinstall the filter, insert it into the unit and replace the filter door.

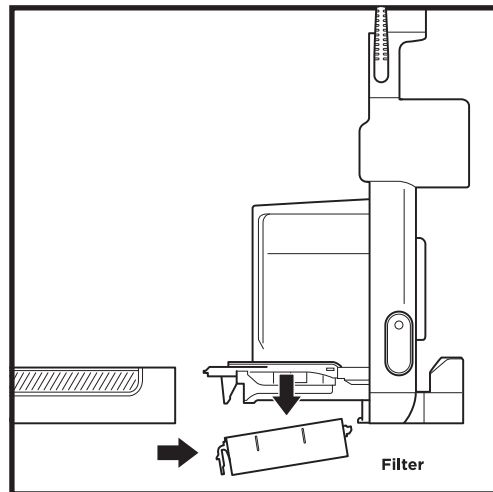

NOTE: The pre-motor filters should be replaced every 2.5 years. The post-motor filter should be replaced every 3 years.

MAINTENANCE

NOZZLE MAINTENANCE

SELF-CLEANING BRUSHROLL

If any hair is wrapped around the brushroll, continue vacuuming, using Carpet/Low Pile mode on a bare floor surface, a low-pile carpet, or a small area rug. This will allow the self-cleaning brushroll to remove the hair wrap and send it to the dust cup.

If you run over a hard or sharp object or notice a noise change while vacuuming, check for blockages or objects caught in the brushroll.

If some fibers remain wrapped around the brushroll after continued use, clear them from the brushroll.

CLEANING THE SOFT ROLLER

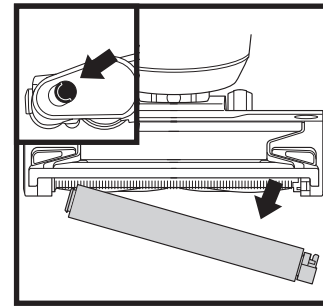

Slide the Soft Roller access button forward to release the Soft Roller.

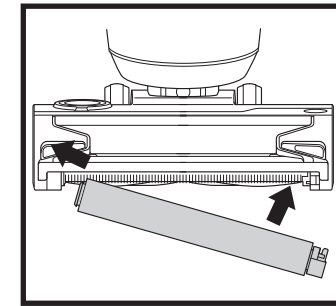

Hand wash the Soft Roller as needed. Use only water, and allow it to air-dry completely for at least 24 hours. Reinsert the Soft Roller in the front of the nozzle until it clicks into place.

CORD MAINTENANCE

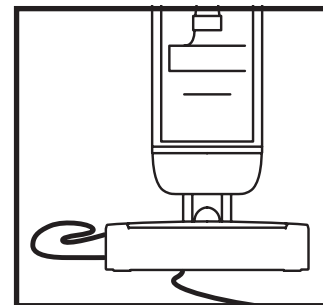

To minimize the risk of power cord damage, **DO NOT** run the vacuum over the power cord. If this occurs, immediately shut off power to the vacuum and remove the cord from the brushroll or nozzle.

1. **DO NOT** pull or carry vacuum cleaner by the cord or use cord as a handle.
2. **DO NOT** unplug by pulling on the cord. Grasp the plug, not the cord.
3. **DO NOT** close the door on the cord.
4. **DO NOT** pull the cord around sharp corners.
5. **DO NOT** leave the cord near heated surfaces.

MAINTENANCE

DETECT SENSOR MAINTENANCE

Make sure to clean the Detect sensors regularly, or when the DirtDetect Indicator is red, as hair and other debris may build up and obstruct the sensors. If the sensors are partially obstructed, Detect mode will not function as expected. To easily access the nozzle for sensor cleaning, press the Powered Lift-Away button to detach the pod, then press the wand release button to detach the wand from the nozzle.

CLEANING THE DIRTDETECT SENSORS

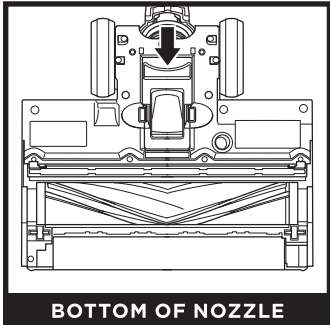

BOTTOM OF NOZZLE

1. Turn the nozzle upside down and locate the nozzle inlet access point between the brushrolls and rear wheels.

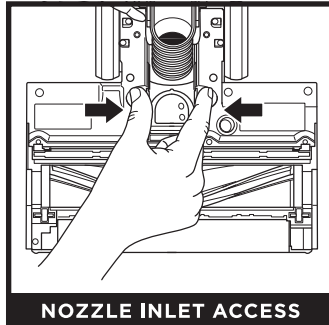

NOZZLE INLET ACCESS

2. Pinch the nozzle hose inlet and pull open the door. Arrows indicate the two small DirtDetect sensors.

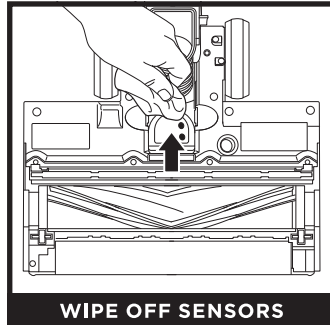

WIPE OFF SENSORS

3. Gently wipe the sensors with a microfiber cloth and remove all hair and debris.

CLEANING THE FLOORDETECT SENSOR

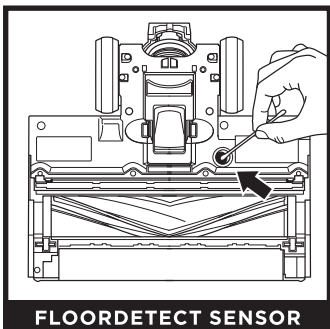

FLOORDETECT SENSOR

1. Locate the FloorDetect sensor on the bottom of the nozzle.
2. Use a cotton swab to wipe away dirt and debris from the sensor and surrounding area.

CLEANING THE EDGEDETECT SENSORS

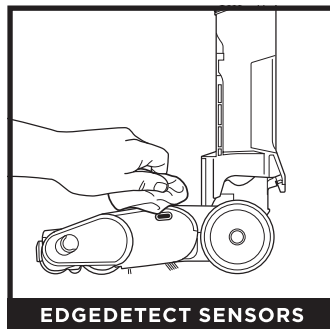

EDGEDETECT SENSORS

1. Locate EdgeDetect sensors on the sides of the nozzle (small clear ovals on the top, rear edge).
2. Check the sensors, and remove any dirt or debris that may be blocking them.
3. Gently wipe the sensors with a microfiber cloth, using a circular motion.

CHECKING FOR BLOCKAGES

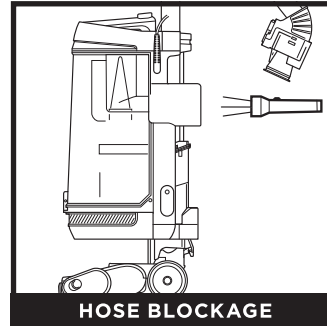

HOSE BLOCKAGE

Detach hose from vacuum pod, and check hose and opening on back of pod for blockages.

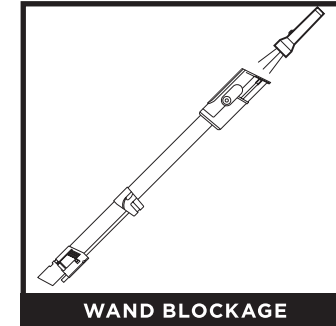

WAND BLOCKAGE

Detach wand from floor nozzle and handle, and check both ends for blockages.

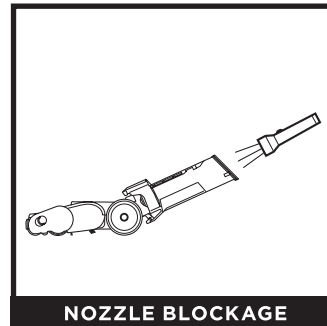

NOZZLE BLOCKAGE

Detach wand from floor nozzle, tilt nozzle neck back, and check opening for blockages.

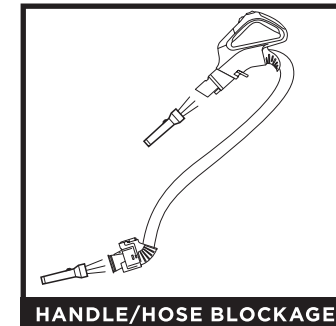

HANDLE/HOSE BLOCKAGE

Detach handle from wand and hose from the vacuum pod, and check openings for blockages.

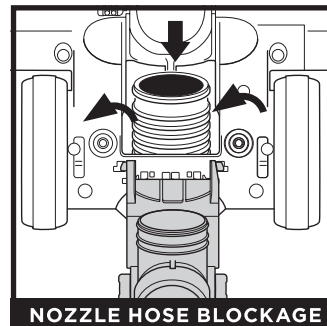

NOZZLE HOSE BLOCKAGE

To access the nozzle hose, pinch the release touchpoints on the bottom of the nozzle, then lift the cover and clear any blockages.

AVAILABLE ACCESSORIES

A Crevice Tool

This slender tool offers extended reach to access corners, baseboards, tight spaces, and ceilings.

B Upholstery Tool

Picks up hair, dust, and large debris from mattresses, couches, curtains, lampshades, and other delicate upholstered fabrics.

C Pet Multi-Tool

A single convertible tool for cleaning tough pet messes two ways: use the stiff bristle brush to clean stuck-on debris, or take off the bristles to reveal an upholstery tool perfect for removing stubborn pet hair and large piles of debris.

D Duster Crevice Tool

Two cleaning tools in one. The crevice tool gives you extended reach to clean in tight spaces, while the soft brush is ideal for dusting delicate surfaces.

E Pet Power Brush

The turbine brush loosens and removes pet hair and debris from carpets, and powerfully deep-cleans dander out of upholstery and other surfaces.

F Under-Appliance Wand

Clean under and behind hard-to-move appliances and furniture with this adjustable 36" tool. Flip the extension piece over to clean the underside of appliances.

G Anti-Allergen Dust Brush

This brush features nylon fiber bristles specifically designed for removing fine dust and allergen particles from the most delicate surfaces.

H HairPro® Self-Cleaning Pet Power Brush

Tackles pet hair and ground-in dirt from above-floor areas like carpeted stairs and upholstery, while actively removing hair wrap as it cleans.

I Home & Car Detail Kit

Deep-clean your car like a professional detailer, or clean hard-to-reach areas in your home. Micro-sized tools let you clean around delicate objects and access the tightest spaces like car vents and computer keyboards.

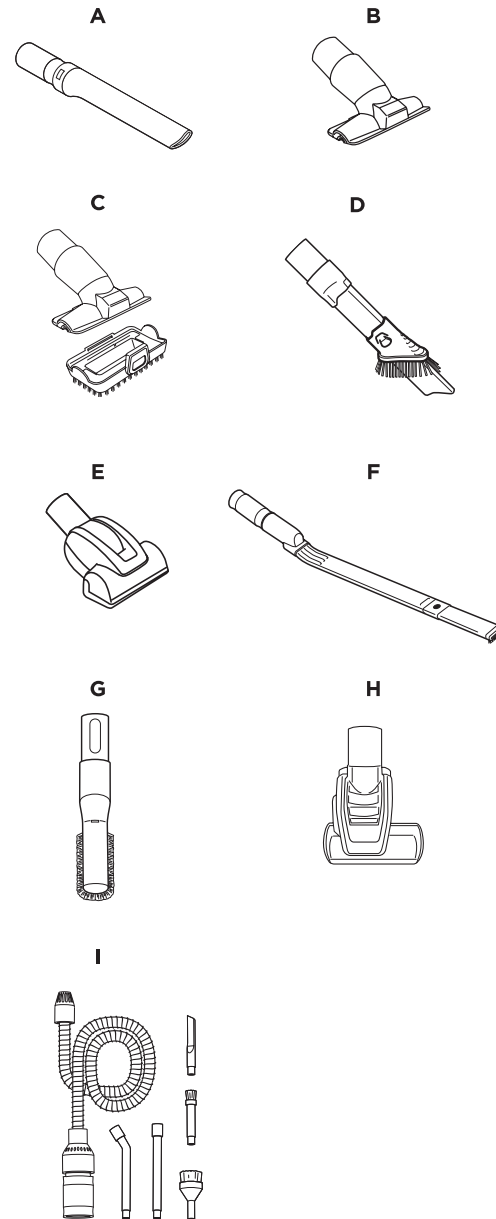

TROUBLESHOOTING

Power cord caught in brushroll or floor nozzle.

- To minimize the risk of power cord damage, DO NOT run the vacuum over the power cord. If this occurs, immediately shut off power to the vacuum and remove the cord from the brushroll or nozzle.
- Inspect power cord and plug for any damage before use. DO NOT use vacuum cleaner with a damaged cord or plug. Turn off all controls before plugging in or unplugging the vacuum cleaner. Store your vacuum cleaner with the power cord secured around the two cord hooks.

Vacuum is not picking up debris. No suction or light suction.

- Check filters to see if they need cleaning. Follow instructions for rinsing and air-drying the filters before reinstalling them.
- Dust cup may be full; empty dust cup.
- Check hose, hose connections, nozzle, wand, pod, and accessories for blockages. Clear any blockages found. See Checking for Blockages section for more information.
- If any hair, string, or carpet fibers are wrapped around the brushroll, extend cleaning time to allow the self-cleaning brushroll to remove them. If some hair or fibers remain wrapped around brushroll after continued use, carefully remove them. See Cleaning the Brushroll section for more information.

Vacuum lifts area rugs.

- Make sure the touchscreen selector on the handle switch is set to the Thick Carpet/Area Rug setting.
- Suction is powerful. Take care when vacuuming area rugs or rugs with delicately sewn edges.

DirtDetect Indicator light not responding.

- Make sure the touchscreen selector on the handle switch is set to Detect Mode. The DirtDetect Indicator will be off in manual surface modes.
- Check sensors located in nozzle inlet to see if there are any blockages (See Detect Sensor Maintenance section for more information.).
- Remove any blockages and clean sensors.

Brushrolls do not spin.

- If the headlight indicator lights turn red, immediately turn off and unplug the vacuum. Remove pod and wand from floor nozzle and clear any blockages. Reconnect nozzle, plug in vacuum, and turn on power.
- With the power on, recline the handle, which will automatically turn on the brushrolls.

Vacuum turns off on its own or headlight indicator light flashes red.

If your vacuum overheats, the thermostat will automatically turn off the motor. Perform the following steps to restart:

- Turn vacuum off and unplug it.
- Empty dust cup and clean filters. See Emptying the Dust Cup and Cleaning and Replacing the Filters sections for more information.
- Check for blockages in hose, wand, floor nozzle, accessories, and inlet openings.
- Allow unit to cool for a minimum of 60 minutes.
- Plug in vacuum and turn it on.

Vacuum is emitting air that smells bad.

- Dust cup may be full; empty dust cup. Empty dust cup after each use for optimal Odour Neutraliser Technology performance.
- Check filters to see if they need cleaning. Follow instructions for rinsing and air-drying the filters before reinstalling them.
- Check to make sure odour cartridge is installed in the dial and the dial is installed in the nozzle.
- Check the Odour Neutraliser Technology dial on the nozzle to see what setting is enabled.
- If Odour Neutraliser Technology dial is at any setting from Low to High and the cartridge has been installed for 6 months or longer, consider replacing it.
- If the odour cartridge is still emitting a scent but you dislike it, consider turning the intensity down, or reinstall the dial in the nozzle without the cartridge.
- If the Odour Neutraliser Technology cartridge is not emitting a scent, consider replacing it.

For all other issues, please go to sharkclean.co.uk/customer-care or call Customer Service 0800 862 0453.

FIVE (5)YEAR LIMITED GUARANTEE

When a consumer buys a product in the UK, they get the benefit of legal rights relating to the quality of the product (your "statutory rights"). You can enforce these rights against your retailer. However, at Shark® we are so confident about the quality of our products that we give you an additional manufacturer's warranty of up to five years (one year as standard, plus a further four years upon registration with Shark®). Offer valid only in United Kingdom and Republic of Ireland. These terms and conditions relate to our manufacturer's guarantee only – your statutory rights are unaffected.

The conditions below describe the prerequisites and scope of our guarantee.

Shark® Guarantees

A household appliance like a vacuum cleaner constitutes a sizeable investment. Your new machine needs to work properly for as long as possible. The guarantee it comes with is an important consideration - and reflects how much confidence the manufacturer has in its product and manufacturing quality.

Every Shark® machine comes with a free shark® parts and labour guarantee. Our customer service helpline (0800 862 0453) is open from 9.00am to 6.00pm Monday - Friday. It's free to call, and you'll be put straight through to a Shark® representative. You'll also find online support at sharkclean.co.uk.

How do I register my extended Shark® guarantee?

If you have purchased your vacuum directly from sharkclean.co.uk your guarantee is registered automatically. You can also register your guarantee at sharkclean.co.uk within 28 days of purchase. To save time, you'll need the following information about your machine:

- Date you purchased the machine (receipt or delivery note)
- Model Number

IMPORTANT

- Your guarantee will only cover your product from the date of purchase.
- Please keep your receipt at all times. Should you need to use your guarantee we will need your receipt to verify the information you have supplied to us is correct. The inability to produce a valid receipt may invalidate your ability to claim against your guarantee.

What are the benefits of registering my free Shark® guarantee?

When you register your guarantee we'll have your details to hand if we ever need to get in touch. You can also receive tips and advice on how to get the best out of your Shark® vacuum and hear the latest news about new Shark® technology and launches.

If you register your guarantee online, you'll get instant confirmation that we've received your details.

How long are new Shark® machines guaranteed for?

Our confidence in our design and quality control means that your new Shark® vacuum cleaner is guaranteed for a total of up to five years (1 year plus an extended guarantee of 4 years on registration).

What is covered by the free Shark® guarantee?

At Shark's discretion repair or replacement of your Shark® machine, including all parts and labour. A Shark® guarantee is in addition to your legal rights as a consumer.

What is not covered by the free Shark® guarantee?

- Blockages - for details of how to unblock your vacuum cleaner, please refer to the Operating Manual.
- Normal wear and tear such as brush bar, fuse, belt etc.
- Accidental damage, faults caused by negligent use or care, misuse, neglect, careless operation or handling of the vacuum cleaner which is not in accordance with the Shark® Operating Manual supplied with your machine.
- Use of the vacuum cleaner for anything other than normal domestic household purposes.
- Use of parts not assembled or installed in accordance with the operating instructions.
- Use of parts and accessories which are not Shark® Genuine Components.
- Faulty installation (except where installed by Shark®).
- Repairs or alterations carried out by parties other than Shark® or its agents.

What happens when my guarantee runs out?

Shark® does not design products to last for a limited time. We do appreciate that there may be a desire for our customers to want to repair their vacuum cleaners after the guarantee has lapsed. In this case please contact our Freephone customer service help line and ask about our out of guarantee program, on 0800 862 0453.

Where can I buy genuine Shark® spares and accessories?

Shark® spares and accessories are developed by the same engineers who developed your Shark® vacuum. You'll find a full range of accessories, spares and replacement parts for all Shark® machines at sharkclean.co.uk. Only use Shark® branded filters and accessories. Damage caused by use of non-Shark parts may not be covered by your guarantee.

NOTES

PLEASE READ CAREFULLY AND KEEP FOR FUTURE REFERENCE.

This Owner's Guide is designed to help you get a complete understanding of your new Shark® POWERDETECT Upright Vacuum with Detect Technology, DuoClean® Detect, Powered Lift-Away®, Anti Hair Wrap Plus, and Anti-Odour Technology.

**SharkNinja Europe Limited,
1st/2nd Floor 3150 Century Way,
Thorpe Park, Leeds, LS15 8ZB, UK
+44 (0)800 862 0453
www.sharkclean.co.uk**

**SharkNinja Germany GmbH,
Rotfeder-Ring 9,
3rd Floor,
60327 Frankfurt am Main, Germany
www.sharkclean.eu**

Illustrations may differ from actual product. We are constantly striving to improve our products; therefore the specifications contained herein are subject to change without notice.

© 2024 SharkNinja Operating LLC. DUOCLEAN, FLOOR DETECT, HAIRPRO, LIFT-AWAY, POWERED LIFT-AWAY, and SHARK are registered trademarks in the United Kingdom of SharkNinja Operating LLC. POWERDETECT is a pending trademark in the United Kingdom of SharkNinja Operating LLC.

AZ3900UKSeries_IB_MP_240514_Mv1
PRINTED IN CHINA

 [@sharkcleaninguk](https://www.facebook.com/sharkcleaninguk)

 [@sharkcleanuk](https://twitter.com/sharkcleanuk)

 [@sharkcleanuk](https://www.instagram.com/sharkcleanuk)