

Shark

Air Purifier

HP150



OWNER'S GUIDE

IMPORTANT SAFETY INSTRUCTIONS

HOUSEHOLD USE ONLY

⚠ WARNING

TO REDUCE THE RISK OF FIRE, ELECTRIC SHOCK, OR INJURY:

GENERAL WARNINGS

- DO NOT** operate any unit with a damaged cord or plug. Consult your local waste authority for information regarding available recycling and/or disposal options.
- DO NOT** run cord under carpeting. **DO NOT** cover cord with throw rugs, runners, or similar coverings. **DO NOT** route cord under furniture or appliances. Keep cord away from high-traffic areas where it will not be tripped over.
- If the power cord is damaged, it must be replaced by the manufacturer, its service agent, or similarly qualified persons in order to avoid a hazard.
- This appliance should only be placed on flat and dry surfaces.
- This appliance is not intended for use by anyone (including children) with reduced physical, sensory or mental capabilities, or lack of experience and knowledge, unless they have been given supervision or instruction concerning use of the appliance by a person responsible for their safety.
- Children should be supervised to ensure that they **DO NOT** play with the appliance.
- Cleaning and user maintenance shall not be made by children without supervision.
- Prior to cleaning or other maintenance, the appliance must be unplugged from the electrical outlet.
- DO NOT** handle plug or appliance with wet hands.
- DO NOT** use without filters in place.
- Only use Shark® branded filters and accessories.
- DO NOT** damage the power cord:
 - DO NOT** pull or carry appliance by the cord or use the cord as a handle.
 - DO NOT** unplug by pulling on cord. Grasp the plug, not the cord.
 - DO NOT** stand the appliance on the power cord, close a door on the cord, pull the cord around sharp corners, or leave the cord near heated surfaces.
- DO NOT** use with any opening blocked; keep free of dust, lint, hair, and anything that may reduce airflow.
- DO NOT** use if airflow is restricted. If the air paths become blocked, turn the appliance off and unplug from electrical outlet. Remove all obstructions before you plug in and turn on the unit again.
- DO NOT** use if appliance is not working as it should, or has been dropped, damaged, left outdoors, or dropped into water.
- DO NOT** place appliance on unstable surfaces such as chairs or tables.
- DO NOT** use in the following areas:
 - Wet or damp surfaces
 - Outdoor areas
 - Spaces that are enclosed and may contain explosive or toxic fumes or vapors (lighter fluid, gasoline, kerosene, paint, paint thinners, mothproofing substances, or flammable dust)
- Turn off all controls before plugging in or unplugging the appliance.
- Unplug from electrical outlet when not in use and before general maintenance or cleaning. For mesh dust filter maintenance, please refer to the mesh dust filter maintenance section.
- Hand wash exterior/hard plastic/non-electronic parts with a damp cloth only. Do not immerse. Cleaning with chemicals could damage the unit.
- Make sure filters are in place after routine maintenance.

ANTI-ODOUR TECHNOLOGY

- Observe the following when interacting with the Anti-Odour Technology cartridge.
 - DO NOT** attempt to disassemble Anti-Odour Technology cartridge.
 - Avoid direct contact with the fragrance pod in the cartridge.
 - DO NOT** directly inhale from the anti-odour technology cartridge.
 - Keep away from children and pets.
 - Keep away from heat, sparks, and open flame.
 - DO NOT** place in direct sunlight.
 - Avoid contact with fabrics and finished surfaces.

FRAGRANCE CARTRIDGE FIRST AID

- Eye contact: Remove contact lenses if present. Rinse continuously with water for several minutes
- Skin contact: Wash hands thoroughly after handling. If irritation or rash develops, seek medical advice/attention.
- Inhalation: Move person to fresh air if they are experiencing any respiratory symptoms. If symptoms persist, seek medical advice/attention.
- Ingestion: **DO NOT** induce vomiting. Seek medical advice/attention.

- Dispose of batteries properly. Keep batteries away from children at all times. Even used batteries can cause injury.

⚠ WARNING: Chemical Burn Hazard. Keep batteries away from children.

This product contains a lithium button/coin cell battery. If a new or used lithium button/coin cell battery is swallowed or enters the body, it can cause severe internal burns and can lead to death in as little as 2 hours. When not changing batteries, keep the battery compartment completely closed. If the battery compartment does not close securely, stop using the product, remove the batteries, and keep them away from children. If you think batteries might have been swallowed or placed inside any part of the body, seek immediate medical attention.

SAVE THESE INSTRUCTIONS

SETTING UP YOUR AIR PURIFIER

Parts:

1. Air Output Vents
2. Anti-Odour Technology Dial
3. Control Panel
4. Front Display
5. Air Purifier Body
6. Air Intake Vents
7. Mesh Dust Filters
8. HEPA Filter
9. HEPA Filter Door



TIPS FOR SETTING UP YOUR AIR PURIFIER

- Make sure the front panel of the air purifier faces away from the closest wall.
- Do not move the unit while it is running. Turn off the power and unplug the air purifier before moving it.
- Make sure the air intake vents are not blocked.
- Do not place anything on the air purifier.
- Do not place the air purifier near heaters or radiators.
- Keep the air purifier out of direct sunlight and away from water or other liquid.
- Keep all nearby doors and windows closed when operating the air purifier.
- Avoid using in very humid environments.

Note: Anti-Odour Technology is not included on all Shark HP150 series products.



1. **DO NOT** plug in the air purifier. First, carefully turn the air purifier upside down and place it on a level floor surface. Rotate the filter door counterclockwise to unlock it, then lift it off to access the HEPA filter.



2. Take the HEPA filter out of its plastic packaging. Reinstall the HEPA filter in either orientation.



3. With the HEPA filter reinstalled, rotate the filter door clockwise until it clicks into place.



4. Set up the air purifier on a flat, level, floor surface, at least 3 inches (8 cm) away from walls and objects.
If Anti-Odour Technology is included with your air purifier, find the odour cartridge and follow the instructions to install it.

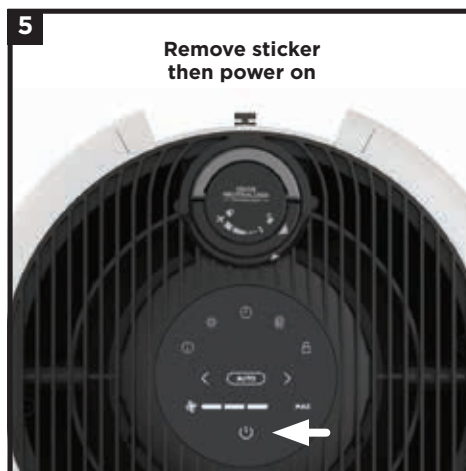

5. Carefully remove the yellow sticker on the top of the air purifier to access the control panel.
Plug the air purifier into an electrical outlet and press the power button on the top control panel.



6. When the air purifier power is on, the air purifier will begin to analyse the air quality, indicated by the rotating lights. After a few seconds, the air purifier will display the current air purification status.

Note: HEPA Filter Technology allows up to 5 years* of use out of a single HEPA filter.

*Tested to GB/T18801-2015 P.CCM, based on 50% CADR decline, 12 sq. m cleaning area and 12 hours daily operation on MAX fan speed.

CONTROL PANEL

There is a control panel on the top of the air purifier and a display screen on the front.

TOP CONTROL PANEL











FRONT DISPLAY SCREEN



Displays the current air purification status based on the Air Info mode selected on the top control panel.



TOP CONTROL PANEL BUTTONS





-  **On/Off:** Press to turn the power on or off.
-  **Auto Mode:** Press to turn on Auto Mode. In this setting the fan speed automatically adjusts based on real-time air purification readings. As the air purification improves, the fan speed will decrease. If it worsens, the fan speed will increase. **Leave your unit in Auto Mode for optimal filter life and performance.**
-  **Fan Speed:** Adjusts the speed of the fan. Select one of 5 settings: 1 Quiet, 2 Low, 3 Medium, 4 High, 5 Maximum. Select by using the arrows on the control panel. Note: If fan speed is manually changed, Auto Mode will be deactivated. For tips and more information, see the Optimising Fan Speed section.
-  **Air Info:** Press to switch between air purification display options. See the Air Info Settings section for more information.
-  **Shut-Off Timer:** Set the number of hours for the air purifier to run before it automatically shuts off. Timer can be set from 1 to 12 hours.
-  **Brightness:** Adjusts the brightness of both the front display screen and the top control panel. Switch between 3 options: full brightness, partially dim, fully dim. In fully dim mode, the air purifier will continue to run with the LED light off—perfect for nighttime.
-  **Dust Filter Life:** Press to show the remaining life of the mesh dust filters before additional maintenance is required. When Dust Filter Life reaches 0%, the filter icon will flash to indicate the mesh dust filters need to be checked for debris buildup. See Mesh Dust Filter Maintenance section for more information.
-  **Child Lock:** Press and hold for two seconds to lock the top control panel buttons. To unlock, press and hold for two seconds again.

Tips and Tricks:

-  **Optimise Performance in Eco Mode:** If 100% air purification status is achieved for 5 minutes in Auto Mode, your air purifier will enter Eco Mode. Your unit's filter life will be optimised.
-  **Turn Off Beeping:** To turn off notification sounds, press and hold the Air Info and Child Lock buttons at the same time for two seconds. To resume, press and hold both buttons again.

AIR INFO SETTINGS

The built-in sensor detects your air purification status to give you real-time information. Use the **AIR INFO** button  to switch between air status display options.

INFO	FRONT DISPLAY SCREEN	REAL-TIME READING
% STATUS		<p>Displays the air purification status rating:</p> <ul style="list-style-type: none"> • Poor: 0%–69% • Fair: 70%–84% • Good: 85%–100% <p>% STATUS uses particulate matter (PM) air purification standards as determined by the EPA (United States Environmental Protection Agency) to calculate the status rating.</p>
PARTICLE SIZES		<p>The PM (particulate matter) value is the amount of particulate in your air, measured in micrograms (µg) per cubic metre. Your air purifier measures three particle sizes, PM1, PM2.5, and PM10.</p>
PM1		<p>Displays the number of PM1-sized particles in your air, including ultra-fine allergens.</p>
PM2.5		<p>Displays the number of PM2.5-sized particles in your air, including smoke.</p>
PM10		<p>Displays the number of PM10-sized particles in your air, including dust, and pollen.</p>

UNDERSTANDING YOUR AIR QUALITY

The rings on the front display will change colour as your air purification status changes, allowing you to easily monitor the purification even when the air purifier is across the room.

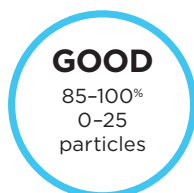

A blue ring means your air purification status is good, with a low level of particle concentration.

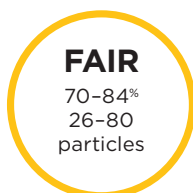

An amber ring means your air purification status is fair, with a moderate level of particle concentration. For better results, increase fan speed or select Auto Mode.

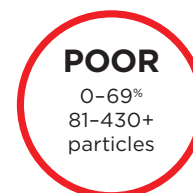

A red ring means your air purification status is poor, with a high level of particle concentration. For better results, increase fan speed or select Auto Mode.

Note: The air purification status sensor uses a cumulative particle count across all particle sizes to determine air purification status.

OPTIMISING FAN SPEED

Your air purifier is equipped with 5 fan speed settings. Adjust fan speed to Optimise your cleaning performance.

DISPLAY	SPEED	BEST FOR
	AUTO	Optimising HEPA filter life
	1-2	Quiet operation
	3-4	Reducing odours.
	5 (MAX)	Maximum purification and debris capture.

TROUBLESHOOTING AND FREQUENTLY ASKED QUESTIONS

Product	What are the recommended settings?	We recommend using this air purifier in Auto Mode. Auto Mode leverages your air purifier's particle sensor, and this adjusts the fan speed automatically. Higher fan speeds work best for reducing odours and capturing debris most effectively.
	Where should I set up my air purifier?	We recommend setting up the air purifier in the room of your home where there is the most activity. This will help to clear the air of pollutants and odours as they are introduced.
	What is Eco mode?	If 100% status is achieved for 5 minutes in Auto Mode, your air purifier will enter Eco Mode. The fan will turn off until a significant number of particles are detected, optimising your HEPA filter's life.
	Can I mute the air purifier, so it doesn't beep when pressing the buttons?	To turn off notification sounds, press and hold the Air Info ⓘ and Child Lock 🔒 buttons at the same time for two seconds. To reactivate sounds, press and hold both buttons for 2 seconds again.
	Why are the top control panel buttons not working?	Your air purifier may have the child lock setting activated. Press and hold the Child Lock 🔒 button for two seconds to turn this setting on or off.
Air Quality	Why is my air purification status always at 100%?	If your air purifier displays a blue ring, your air purification status is good. However, air purification status will fluctuate as you introduce pollutants into your home. Activities like smoking, cooking, dusting, or spraying cleaning products (among other things) can add pollutants to your air. Our Clean Sense IQ technology tracks this fluctuation in real time and adjusts as it detects particles. To determine if the sensor is working correctly, spray a small amount of perfume or aerosol cleaning product near the sensor on the back of the air purifier. Please visit support.sharkclean.co.uk for more information.
	Why is my air purification status never at 100%?	If your air purification status never reaches 100%, make sure that the HEPA filter is properly installed and that its original plastic packaging has been removed. Activities like smoking, burning candles, running a humidifier, opening windows, and cooking (among other things) can add more pollutants to your air. Make sure to survey your environment and remove anything that could be causing low air purification status. We also recommend turning off the unit and unplugging. Then locating the air status sensor on the back side of the air purifier and using a hand vacuum hose with attachment to clean the area around the air status sensor.
Mesh Dust Filter	What are these filters on both sides of the air purifier for?	These easy-to-clean mesh dust filters capture large debris like hair, dust, and lint to protect the 3-layer HEPA filter. Maintenance is required on these mesh dust filters when indicated on the front display. Refer to the Mesh Dust Filter Maintenance section for more information.
	How do I know when to clean these 2 filters?	When the mesh dust filters need maintenance, the front display will show a pulsing red ring along with the text "check dust filters." Refer to the Mesh Dust Filter Maintenance section for more information.
HEPA Filter	Can I wash the HEPA filter?	No, the HEPA filter is not washable. Keep filter away from water.

Customer Service

For further assistance, call 0800 862 0453.

Note: Anti-Odour Technology is not included on all Shark HP150 series products.

Checking the Mesh Dust Filters:

When the mesh dust filters need maintenance, the front display will show the following screen with a pulsing red ring:



Cleaning the Mesh Dust Filters:

When the Check Dust Filters message appears on the front display, remove the dust filters and inspect them for debris. If maintenance is required, be sure to **KEEP THE AIR PURIFIER PLUGGED IN** and running, and complete the following steps:



Gently slide up the filters to remove them. Check the screens for dust and debris buildup.

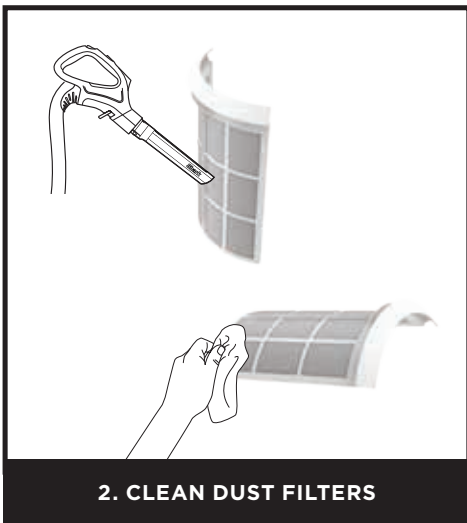

Use a **vacuum cleaner** on low power with a soft brush attachment OR a **cloth/towel** to remove debris from the mesh screens. **DO NOT use abrasive chemical cleaners.**



If additional cleaning is required, switch off the air purifier and rinse the mesh dust filters with room temperature tap water. Be sure to completely dry the screens for 12 hours before reinstalling. **DO NOT USE** the air purifier when mesh filters are wet.



Ensure that the air purifier is switched on and gently reinsert the mesh dust filters into the slots on the sides. Be sure to push each dust filter into place until it is flush with the air purifier body.



Once both mesh dust filters have been cleaned and reinstalled, the air purifier will recalibrate and begin to analyse air purification status, indicated by the rotating lights.

Note: To manually reset the Check Dust Filters indicator, press and hold the filter icon on the top control panel for 1-2 seconds.



Note: The HEPA Filter Technology allows up to 5 years* of use out of a single HEPA filter.

*Tested to GB/T18801-2015 P.CCM, based on 50% CADR decline, 12 sq. m cleaning area and 12 hours daily operation on MAX fan speed.

MAINTAINING YOUR AIR PURIFIER

NOTE: Unplug the air purifier whenever doing any cleaning or maintenance (other than checking the mesh dust filters.)

Exterior Cleaning:

For best results, clean the exterior every two months or as needed. Use a microfiber cloth to remove dust. To clean, wipe down the exterior with a microfiber cloth dampened with warm, soapy water. Avoid excess water and abrasive chemical cleaners to prevent damage.



Interior Cleaning:

For best results, clean the interior of the air purifier every two months or as needed. Remove the filter door, take out the HEPA filter, and use a vacuum cleaner or a microfiber cloth to remove dust and debris from the interior. **DO NOT** use abrasive chemical cleaners or water on the inside of the air purifier.



ANTI-ODOUR TECHNOLOGY

NOTE: Anti-Odour Technology is not included on all Shark HP150 series products.

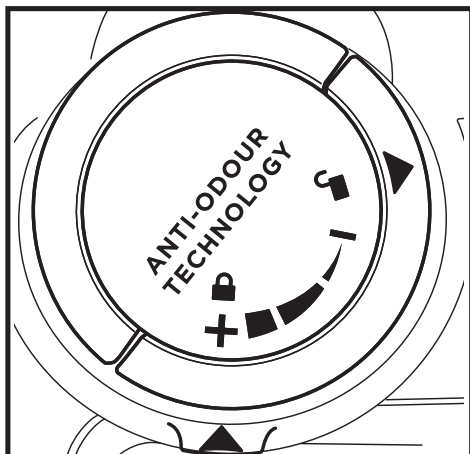

1. OPEN THE PACKAGED ODOUR CARTRIDGE ASSEMBLY

Remove the odour cartridge assembly from the cardboard box and can.

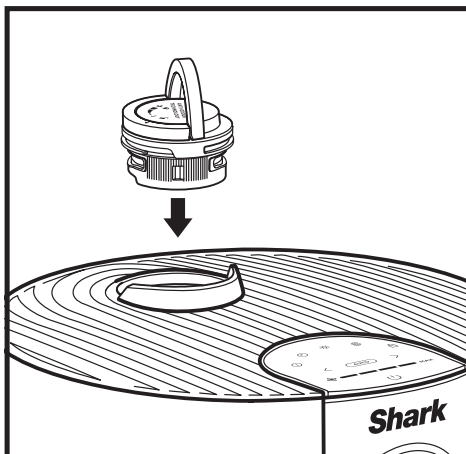

2. INSERT ODOUR CARTRIDGE ASSEMBLY INTO AIR PURIFIER

Flip up the handle on the odour dial, align the arrows, then insert the assembly into the air purifier.

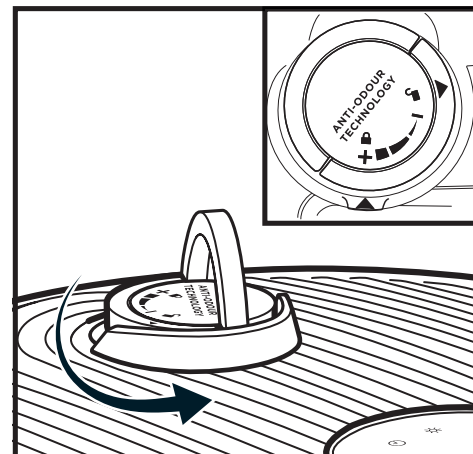

3. ROTATE UNTIL CLICK

To lock and engage the odour cartridge assembly, rotate it counterclockwise until it clicks at least once. Continue to rotate the dial toward the high position to increase the intensity.

SETTINGS

Settings: The Anti-Odour Technology dial has 4 intensity settings: Low, Medium, High, and Off.

ODOUR DIAL POSITION	CLICKS	SETTING	RECOMMENDED FOR
	1	OFF	<ul style="list-style-type: none"> When you are not actively looking to reduce odours. This will extend the life of the odour cartridge.
	2	LOW	<ul style="list-style-type: none"> Mild odour events such as bin smells. Small spaces like a bathroom or entryway.
	3	MEDIUM	<ul style="list-style-type: none"> Strong odour events such as cooking or pet smells. Mid-sized spaces like a bedroom or kitchen.
	4	HIGH	<ul style="list-style-type: none"> Optimal odour-reducing performance. Extreme odour events such as smoke or lingering burnt smells. Large spaces like a living room.

Note: Adjusting the fan speed is another way to control Anti-Odour Technology intensity. See the Optimising Fan Speed section for more information.

LOW
Rotate the dial to the Low position to decrease intensity to the lowest level when in use.

HIGH
Rotate the dial to the High position to increase intensity to the highest level when in use.

TIPS

Odour Cartridge Removal

- The odour cartridge can be removed if you don't want to use the Anti-Odour Technology.
- To remove the cartridge, first remove the odour cartridge assembly from the air purifier. Flip up the handle on the odour cartridge assembly and rotate clockwise until the two arrows are aligned. Pull the handle up and remove from the air purifier.
- Hold the odour cartridge assembly so that the coloured base is visible and rotate the cartridge anticlockwise in the dial housing to remove.
- The dial housing can then be inserted into the air purifier.

Maintenance Required

- Replace the cartridge as recommended under Odour Cartridge Replacement.
- Visit sharkclean.co.uk/shark-parts-accessories/ to learn more and purchase replacements.

Fragrance Strength Over Time

- The intensity of the Anti-Odour Technology's fragrance may diminish over time. It may also have no noticeable fragrance at all. This is natural and does not indicate that the technology is not working. Follow replacement instructions to ensure continued performance.

ANTI-ODOUR TECHNOLOGY REPLACEMENT

NOTE: Anti-Odour Technology is not included on all Shark HP150 series products.

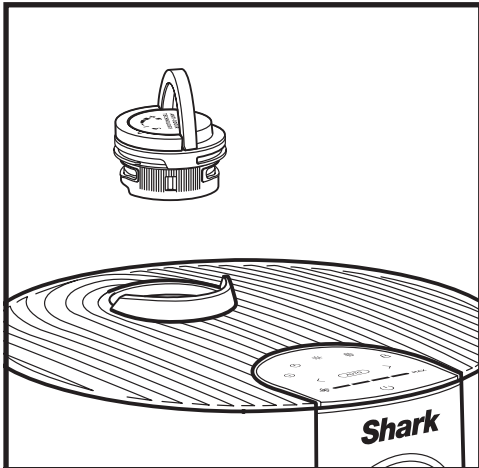

1. REMOVE THE ODOUR CARTRIDGE ASSEMBLY

Flip up the handle and rotate the dial counterclockwise until the two arrows are aligned. Pull the handle to remove the dial from the air purifier.

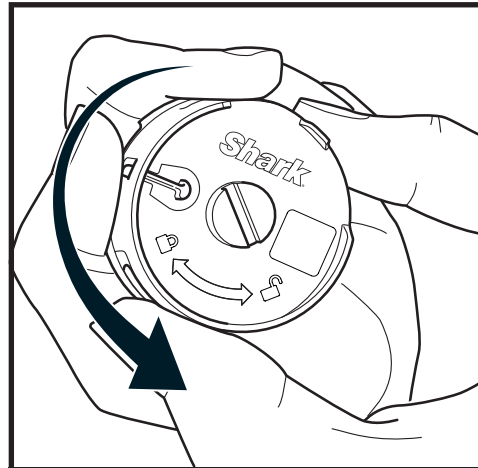

2. REMOVE OLD ODOUR CARTRIDGE

Rotate the cartridge counterclockwise in the dial housing and pull out the cartridge to remove it.

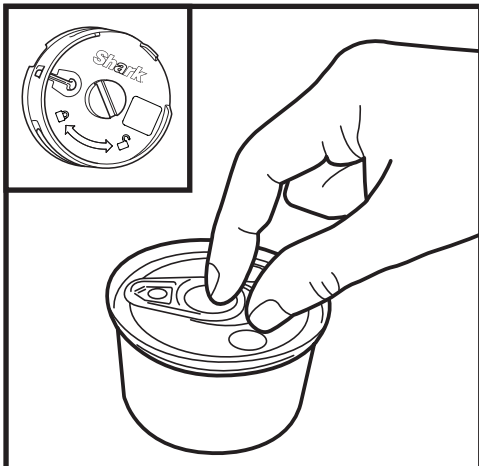

3. REMOVE NEW CARTRIDGE FROM CAN

Remove the new odour cartridge from the sealed packaging. To maintain the life of the cartridge, keep it in the sealed packaging until you are ready to install it.

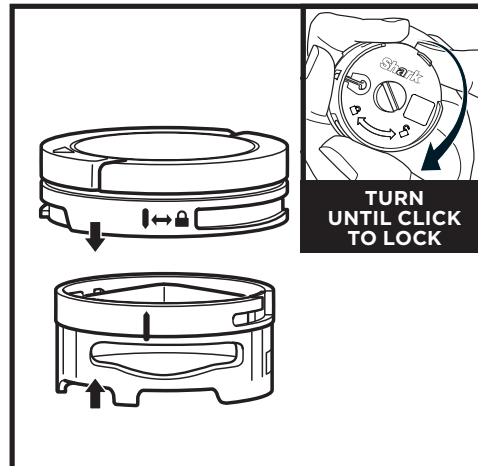

4. INSTALL NEW CARTRIDGE IN DIAL

Align the yellow arrow on the side of the cartridge with the yellow arrow on the side of the dial cover, then insert the cartridge into the dial. Rotate the cartridge clockwise to lock it in place.

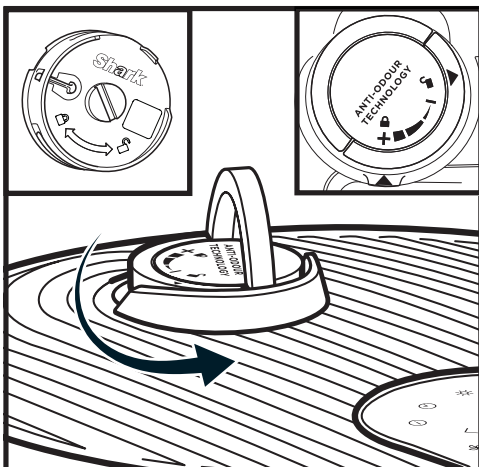

5. INSTALL THE ODOUR DIAL ASSEMBLY

Align the arrow on the dial cover with the arrow on the air purifier, then reinsert the dial into the air purifier. Rotate the dial counterclockwise until it clicks into an intensity setting to engage. Rotate further to change the intensity setting.

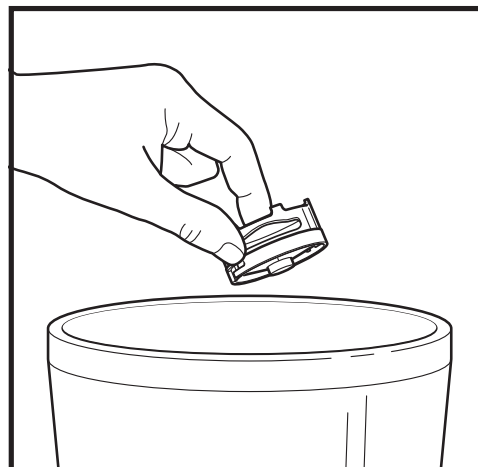

6. USED CARTRIDGE DISPOSAL

Dispose of the old cartridge by dropping it into the bin.

Note: Odour cartridges should be replaced every 3 months or as needed for optimal Anti-Odour Technology performance.

AVAILABLE ACCESSORIES

ORDER ADDITIONAL ACCESSORIES

Additional accessories and replacement filters are available on sharkclean.co.uk/shark-parts-accessories/



Anti-Odour Technology Cartridges (2)

Two replacement cartridges that guard against bad odours for a fresher-smelling home. We recommend replacing cartridges every 3 months or as needed in your air purifier. Anti-Odour Technology intensity dial sold separately.



Remote Control

Use the remote control to operate your air purifier from a distance.

REMOTE CONTROL BUTTONS

- 1. On/Off:** Turns the air purifier on/off.
- 2. Air Info:** Switch between air purification status display options.
- 3. Auto:** Enables Auto Mode.
- 4. Brightness:** Adjusts brightness.
- 5. Fan Speed:** Adjusts fan speed.
- 6. Shut-Off Timer:** Sets shut-off timer.



MANUFACTURER'S GUARANTEE

When a consumer buys a product in the country of purchase, they get the benefit of legal rights relating to the quality of the product (your "legal rights"). You can enforce your legal rights against your retailer, including Shark if you bought your Shark appliance from sharkclean.co.uk. However, at Shark we are so confident about the quality of our products that we give the owner an additional, free parts and labour manufacturer's guarantee of up to 2 years.

A household appliance like a Shark aircare appliance constitutes a sizeable investment. Your new machine needs to work properly for as long as possible. The guarantee it comes with is an important consideration - and reflects how much confidence the manufacturer has in its product and manufacturing quality.

The manufacturer's guarantee does not affect your legal rights.

How long are new Shark machines guaranteed for?

Our manufacturer's guarantee lasts for one year from the date of purchase as standard, or for two years if you register your purchase with us within 28 days. There is information on how to register below.

How do I register my Shark guarantee?

If you have purchased your Shark aircare appliance directly from sharkclean.co.uk your guarantee is registered automatically. If you bought it from anywhere else, you can register your guarantee online within 28 days of purchase.

- To register online, please visit www.sharkclean.co.uk/register-guarantee
- Keep a note of the date you purchased the machine.

IMPORTANT:

- Keep your receipt** if you bought your Shark aircare appliance from anywhere except sharkclean.co.uk. You will need it to claim under your guarantee.
- The free Shark guarantee only applies to Shark owners living permanently in the UK.

What are the benefits of registering my free Shark guarantee?

When you register your guarantee, you will get an extra year of cover. We'll also have your details to hand if we ever need to get in touch. If you further agree to receive communications from us, you can also receive tips and advice on how to get the best out of your Shark aircare appliance and hear the latest news about new Shark technology and launches.

What is covered by the free Shark guarantee?

Repair or replacement (at Shark's option) of your Shark machine, including all parts and labour.

What is not covered by the free Shark guarantee?

- Normal wear and tear.
- Accidental damage or faults caused by negligent use or care, misuse, neglect, careless operation or handling of the Shark appliance which is not in accordance with the Shark Operating Manual supplied with your machine.
- Damage caused by use of the Shark appliance for anything other than normal domestic household purposes.
- Damage caused by use of parts not assembled or installed in accordance with the operating instructions.
- Damage caused by use of parts and accessories which are not Shark Genuine Components
- Faulty installation (except where installed by Shark).
- Repairs or alterations carried out by parties other than Shark or its agents.

How can I claim under the free Shark guarantee?

Contact our customer service helpline on 0800 862 0453. For service hours please visit our website under 'Contact Us'. It's free to call, and you'll be put straight through to a Shark representative. You'll also find online support at <https://support.sharkclean.co.uk/>. The Shark representative will go through some troubleshooting with you, and if we conclude that the item has failed, we will send you a replacement part or a returns label to send the defective item back to us free of charge. When you have delivered the defective product to us, we will send you a replacement.

Please remember that **the item will need to be boxed when you return it to us**, which can be any suitable box; it does not have to be the original packaging.

Where can I buy genuine Shark spares and accessories?

Shark spares and accessories are developed by the same engineers who developed your Shark aircare appliance. You'll find a full range of Shark spares, replacement parts and accessories for all Shark machines at www.sharkclean.co.uk. Please remember that damage caused by the use of non-Shark spares may not be covered under your guarantee.

IMPORTANT INFORMATION

REGISTER YOUR PURCHASE



registeryourshark.com

RECORD THIS INFORMATION

Model Number: _____

Serial Number: _____

Date of Purchase: _____
(Keep receipt)

Store of Purchase: _____

TECHNICAL SPECIFICATIONS

Voltage: 220-240V 50-60Hz
Watts: 26W

Benefits of registering your product and creating an account:

- Get easier, faster product support and access to warranty information
- Access troubleshooting and product care instructions
- Be among the first to know about exclusive product promotions

TIP: You can find the model and serial numbers on the QR code label on the bottom of the unit.

BATTERY REMOVAL AND DISPOSAL

This product's remote control uses a lithium button battery. When the battery no longer has a charge, it should be removed from the remote and recycled. **DO NOT incinerate or compost the battery.**

When your lithium battery needs to be replaced, dispose of it or recycle it in accordance with local ordinances or regulations. In some areas, it is illegal to place spent lithium batteries in the bin or in a municipal solid waste stream. Return spent battery to an authorised recycling center or to retailer for recycling. Contact your local recycling center for information on where to drop off the spent battery.

PLEASE READ CAREFULLY AND KEEP FOR FUTURE REFERENCE.

This Instruction Guide is designed to help you get a complete understanding of your new Shark® Air Purifier.

SharkNinja Europe Limited,
3150 Century Way, Thorpe Park,
Leeds, LS15 8ZB, UK
+44 (0)800 862 0453
www.sharkclean.co.uk

SharkNinja Germany GmbH,
Rotfeder-Ring 9,
60327 Frankfurt am Main,
Germany
www.sharkclean.eu

Illustrations may differ from actual product. We are constantly striving to improve our products; therefore the specifications contained herein are subject to change without notice.

© 2023 SharkNinja Operating LLC. SHARK is a registered trademark in the United Kingdom of SharkNinja Operating LLC.