

# ***Shark*** **STEAM & SCRUB**

Scrubbing & Sanitising Steam Blaster Mop

---

**S8201**  
**SERIES**

---

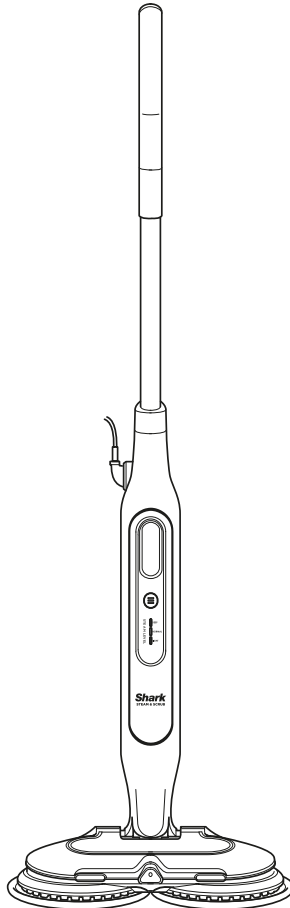

## THANK YOU for purchasing the Shark Steam and Scrub Mop



**TIP:** You can find the model and serial numbers on the QR code label on the back of the steam pod.

### REGISTER YOUR PURCHASE

-  [sharkclean.co.uk/register-guarantee](http://sharkclean.co.uk/register-guarantee)
-  0800 862 0453
-  Scan QR code using mobile device

Benefits of registering your product and creating an account:

- Get easier, faster product support and access to warranty information
- Access troubleshooting and product care instructions
- Be among the first to know about exclusive product promotions

### RECORD THIS INFORMATION

Model Number: \_\_\_\_\_

Serial Number: \_\_\_\_\_

Date of Purchase: \_\_\_\_\_  
(Keep receipt)

Store of Purchase: \_\_\_\_\_

### TECHNICAL SPECIFICATIONS:

Voltage: 220-240V, 50-60Hz  
Watts: 1120W  
Water Capacity: 350 ml (11.8 oz.)

### PLEASE READ CAREFULLY AND KEEP FOR FUTURE REFERENCE.

This instruction manual is designed to help you get a complete understanding of your new Steam and Scrub Mop.

If you have any questions, please call the Customer service line on 0800 862 0453.



IPX4



## CONTENTS

<b>Important Safety Instructions</b> .....	<b>4</b>
<b>What's Included</b> .....	<b>6</b>
<b>Assembling Your Steam and Scrub Mop</b> .....	<b>7</b>
<b>Using Your Steam and Scrub Mop</b> .....	<b>8</b>
<b>Intelligent Steam Control</b> .....	<b>9</b>
<b>Caring For Your Steam and Scrub Mop</b> .....	<b>10</b>
<b>Troubleshooting</b> .....	<b>11</b>
<b>Frequently Asked Questions</b> .....	<b>12</b>
<b>Guarantee</b> .....	<b>13</b>
<b>Notes</b> .....	<b>14</b>



This marking indicates that this product should not be disposed with other household wastes throughout the UK. To prevent possible harm to the environment or human health from uncontrolled waste disposal, recycle it responsibly to promote the sustainable reuse of material sources. To return your used device, please use the return and collection systems or contact the retailer where this product was purchased. They can take this product for environmentally safe recycling.

Thank you for purchasing the Shark Steam and Scrub Mop.

This Owner's Guide is designed to help you get a complete understanding of your new Shark® steam mop. Please read it carefully and keep for future reference.

For a list of what is included with this model, refer to inside flap of box.

If you should have a question about your Shark Steam and Scrub Mop, please call Shark® Customer Service at 0800 862 0453.

# IMPORTANT SAFETY INSTRUCTIONS

FOR HOUSEHOLD USE ONLY

**⚠ WARNING** This appliance is not intended for use by persons with reduced physical, sensory or mental capacities, or lack of experience and knowledge, unless they have been given supervision or instruction concerning use of the appliance by a person responsible for their safety. Children should not use or play with this appliance. Close supervision is necessary to keep appliance out of reach of children during use. We recommend that you check the use and care instructions from the floor manufacturer before using your Steam and Scrub mop.



**WARNING:** Danger of scalding. The steam emitted from the steam mop is very hot and may cause scalding. Please use caution when using the steam and scrub mop.



**WARNING:** Keep steam mop away from children.



**WARNING:** Children should be supervised to ensure that they do not play with the appliance.

1. This appliance can be used by persons with reduced physical, sensory or mental capabilities or lack of experience and knowledge if they have been given supervision or instruction concerning use of the appliance in a safe way and understand the hazards involved. Cleaning and user maintenance should not be done by children. Keep the appliance and its cord out of reach of children. **DO NOT** allow to be used as a toy. Close supervision is necessary when used near children.
2. Keep the appliance out of reach of children when it is energised or cooling down.
3. When in use, **NEVER** turn the Steam and Scrub Mop over on its side or direct steam toward people, pets or plants. Liquid or steam must not be directed towards equipment containing electrical components, such as the interior of ovens.
4. The filling aperture should not be opened during use.
5. Use the system **ONLY** for its intended purpose.
6. **DO NOT** use to heat a room.
7. **DO NOT** use outdoors.
8. **DO NOT** leave the Steam and Scrub Mop unattended when plugged in. **ALWAYS** unplug the power cord from the electrical socket when not in use and before servicing.
9. **DO NOT** allow the Steam and Scrub Mop to be used by children. Close attention is necessary when used near children, pets or plants.
10. Use **ONLY** as described in this instruction manual.
11. Use **ONLY** manufacturer's recommended accessories.
12. **DO NOT** use with damaged cord or plug. If the Steam and Scrub

Mop is not working as it should or has been dropped, damaged, left outdoors or immersed in water, return it to SharkNinja Europe Limited for examination and repair. Incorrect reassembly or repair can cause a risk of electrical shock or injury when the Steam and Scrub Mop is used.

13. To protect against a risk of electric shock, **DO NOT** immerse the Steam and Scrub Mop in water or any other liquid.
14. **DO NOT** handle the plug or Steam and Scrub Mop with wet hands or operate it without wearing shoes.
15. **DO NOT** pull or carry by cord, use cord as a handle, close a door on cord or pull cord around sharp edges or corners. **DO NOT** run Steam and Scrub Mop over cord. Keep cord away from heated surfaces.
16. **DO NOT** unplug by pulling on power cord. To unplug, grasp the plug and pull out of the plug socket. **DO NOT** use extension cords or sockets with inadequate current-carrying capacity.
17. **DO NOT** put any objects into the steam nozzle openings. Discontinue use if the steam nozzle is blocked.
18. **DO NOT** put hands or feet under the Steam and Scrub Mop as it gets very hot.
19. Use the Steam and Scrub Mop **ONLY** on flat, horizontal surfaces. **DO NOT** use on walls, counters or windows.
20. **DO NOT** use on leather, wax-polished furniture, synthetic fabrics, velvet or other delicate, steam-sensitive materials.
21. **DO NOT** add cleaning solutions, scented perfumes, oils or any other chemicals to the water used in the Steam Mop as this will void your warranty and may damage it or make it unsafe for use. If you live in a hard-water area, we recommend using distilled water in your Steam Mop.
22. **NEVER** store or leave Steam and Scrub Mop in one spot with Dirt Grip pad attached, as this may damage surfaces.
23. Before removing Dirt Grip pad, unplug the Steam and Scrub Mop and allow it to cool.
24. Unplug the Steam and Scrub Mop before cleaning. Use a dry or damp cloth to clean the exterior. **DO NOT** pour water on Steam and Scrub Mop or use alcohol, benzene or paint thinner to clean.

# SAVE THESE INSTRUCTIONS

READ CAREFULLY BEFORE USE

25. Extreme caution should be exercised when using the Steam and Scrub Mop to clean stairs.
26. **NEVER** use Steam and Scrub Mop without the Dirt Grip pad attached.
27. Keep your work area well lit.
28. Store Steam and Scrub Mop indoors in a cool, dry place.
29. To avoid circuit overload, **DO NOT** operate another appliance on the same socket (circuit) as the Steam and Scrub Mop.
30. To avoid scalding injuries, **ALWAYS** unplug the Steam and Scrub Mop and allow it to cool before removing or changing mop heads, accessories or Dirt Grip pads.
31. Your Steam and Scrub Mop is designed to clean hard floor surfaces that will withstand high heat. **DO NOT** use on unsealed wood or unglazed ceramic floors. On surfaces that have been treated with wax and on some no-wax floors, the sheen may be removed by the heat and steam action. We recommend that you check the use and care instructions from the floor manufacturer before using your Steam and Scrub mop. Do not operate the appliance if it is leaking.
32. Keep hair, loose clothing, fingers, and all parts of body away from openings and moving parts.
33. **DO NOT** carry the steam mop while in use.

## WHAT'S INCLUDED

- A** Steam Mop Handle
- B** Steam Trigger
- C** Quick-Release Cord Holder
- D** Mop Pole
- E** Water Tank
- F** Mode Button
- G** Mop Head
- H** Steam Blaster
- I** Dirt Grip Soft Scrub Pads

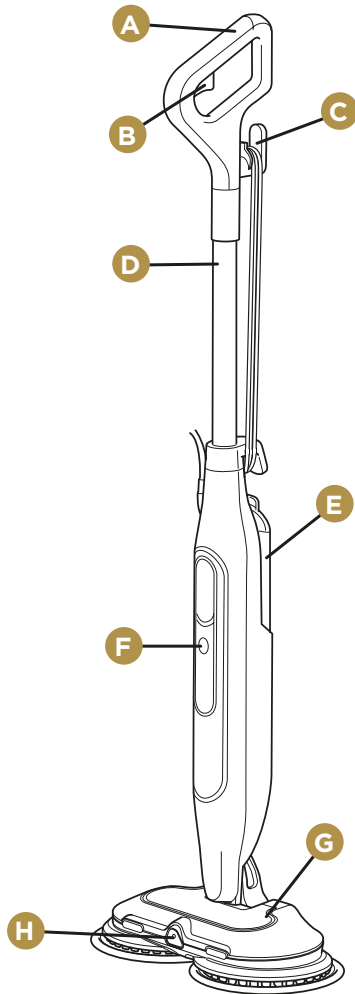
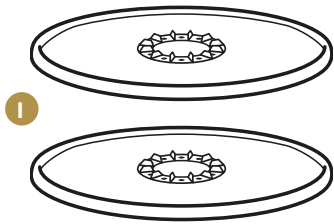

**Note:** For additional pads, please visit [sharkclean.co.uk](http://sharkclean.co.uk)

## ASSEMBLING YOUR STEAM AND SCRUB MOP

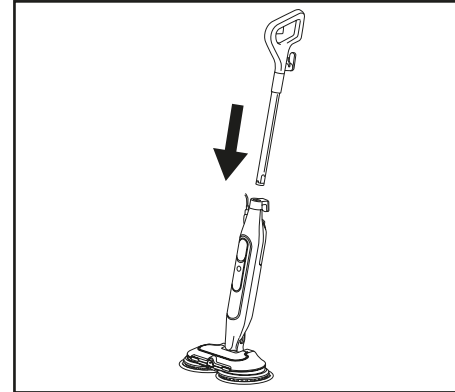

1. Insert the **Mop Handle** into the **Steam Mop Body** until it clicks into place.

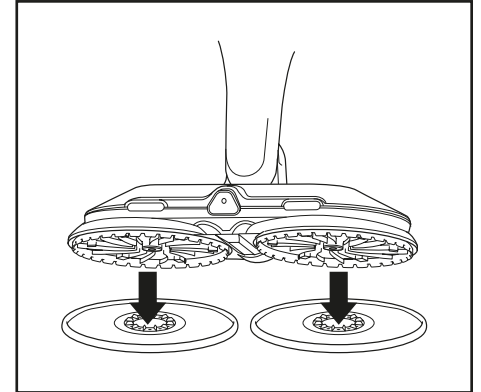

2. To attach the **Dirt Grip Soft Scrub Pads**, place **BOTH** pads flat on the floor with plastic rings facing up. Align the unit directly over the plastic rings on the pads. Gently lower the **Mop Head** onto the pads, pressing until the pads are secure.

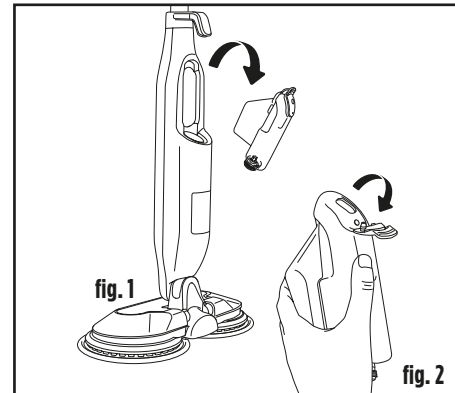

3. Unplug the steam mop before filling the **Water Tank**. To remove the tank, pull it out, away from the mop body. Pull the top rubber fill cap back and with cold or normal temperature water **ONLY**.

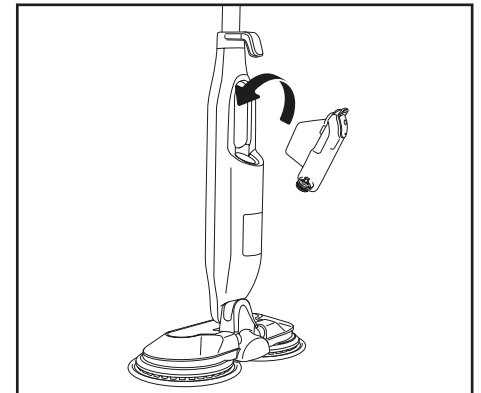

4. When the tank is filled, reinstall it by inserting it back into the mop body.

**Note:** Adding chemicals or cleaning solutions (including vinegar) may damage the steam mop and could be unsafe for you, your family and your pets.

## USING YOUR STEAM AND SCRUB MOP

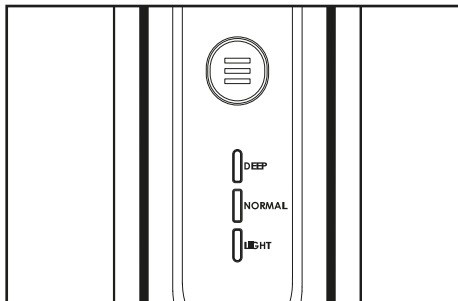
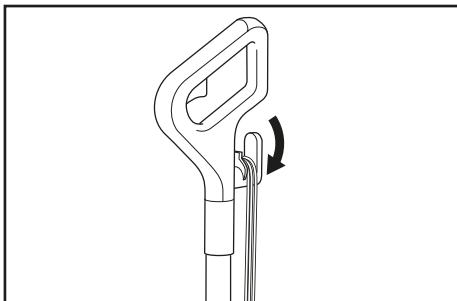

1. Twist the quick-release cord holder to unwrap the power cord completely. Plug into an electrical socket.

2. Once plugged in, the mop will be in Standby mode and all 3 steam level lights will blink. Press the Mode Button to select Light, Normal, or Deep level, then wait 20 seconds to allow steam to release.

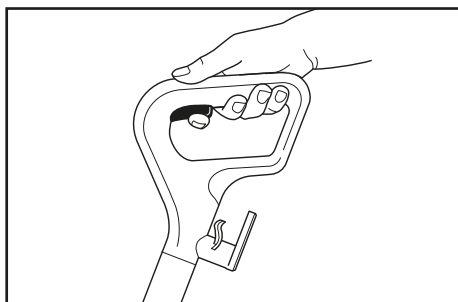
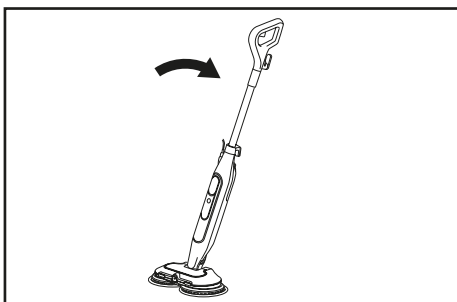

3. Tilt the handle down to activate the spinning pads.

4. To activate the Steam Blaster, press the spray trigger on the handle to blast away tough stains.

## INTELLIGENT STEAM CONTROL

The Shark Steam Mop has 3 intelligent Steam Control settings so you can select the ideal amount of steam to use for each cleaning task. In **NORMAL** mode, the pads will spin faster, and more steam will be produced than in **LIGHT** mode. In **DEEP** mode, the pads will be spinning the fastest and the maximum amount of steam will be produced. Press the Mode button to select the steam level.

SETTING	IDEAL FOR THESE SEALED SURFACES	RECOMMENDED USAGE
  	Laminate Hardwood Vinyl	Cleaning delicate surfaces Light cleaning and dusting Loosening and lifting light dirt
  	Marble Tile Stone	Basic, everyday cleaning. Cleaning large areas. Cleaning moderate and heavy-traffic areas.
  	Marble Tile Stone	Reaching hard-to-clean surfaces. Tough cleaning and removing stuck-on messes and stains. Deep cleaning heavy-traffic areas. Cutting through heavy dirt and grime and sanitising* floors.

### STEAM BLASTER:

1. To target tough messes with an extra burst of cleaning power, move the front of the nozzle 5 to 10 centimeters from the mess (**fig. 3**), then press and hold the Steam Blaster button as needed. (Hold longer for the toughest messes.)
2. Before scrubbing, wait 5 seconds to let the steam blast penetrate the mess.

**Tip:** For more difficult messes, allow 20 seconds or more.

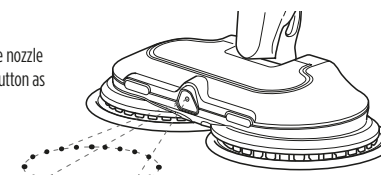

fig. 3

### TO SANITISE FLOORS\*:

1. Attach clean Dirt Grip Soft Scrub Pads to the scrubbing mop head.
2. Plug in the unit, tilt the mop handle down towards you, and press the mode button to select the **NORMAL** setting. The pads will then start spinning.
3. Wait at least 20 seconds for the unit to begin producing steam.
4. **To ready the unit for sanitisation**, start mopping with a forward and backward motion on an appropriate sealed hard floor surface. After three minutes, your unit will be ready to sanitise.
5. Move the mop head slowly and evenly over the area to be sanitised while applying continuous downward pressure. Slowly repeat, making sure to cover the entire area to be sanitised with at least 15 strokes.

\*Sanitisation studies were conducted under controlled test conditions. Be certain to follow all directions for use carefully to fully sanitise with mop head set in the **NORMAL** mode.

## CARING FOR YOUR STEAM AND SCRUB MOP

### AFTER USE AND STORAGE

1. Press the mode button until the settings lights start to blink, indicating that you are in Standby mode. Unplug the cord from the socket and place the steam mop into the upright position. Allow it to cool completely. (fig. 4).
2. When the pads have cooled completely, remove them by pulling them off the discs. Watch out for sharp edges to avoid hurting your fingers. (fig. 5).
3. After the unit has cooled and the steam has been released, empty the water tank before storing. Open the tank lid and pour the water out into a sink or bathtub. After all the water has drained out, close the lid.
4. To store the steam mop, wait until after it has cooled and the steam has been released. Lock the steam mop in an upright standing position by raising the handle until the pole is standing straight up, perpendicular to the ground. With the unit locked in the upright standing position, store it in a dry, protected area (e.g., in a closet or the corner of a room) until next use.

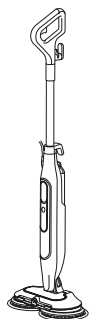

fig. 4

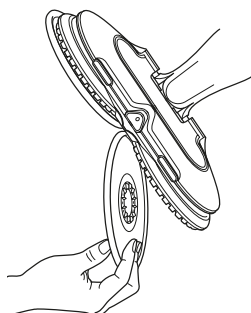

fig. 5

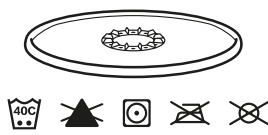

fig. 6

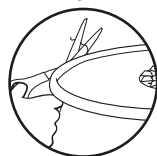

fig. 7

### DIRT GRIP SOFT SCRUB PADS CARE INSTRUCTIONS

**Care**  
Machine-wash the Dirt Grip Soft Scrub Pads separately with warm water, using liquid detergent. Do not clean pads in a dishwasher, as some detergents may cause the pads to leave streak marks on the floor.

### NEVER USE BLEACH, POWDERED DETERGENT, OR FABRIC SOFTENERS

This will damage the Dirt Grip Soft Scrub Pads or leave a coating that will reduce their cleaning performance and absorbency. The pads should be line-dried or tumble-dried on a low setting, as this will extend the life of the microfiber fabric. (fig. 6).

Loose fibers can indicate wearing of the microfiber fabric. **DO NOT** pull the loose fibers, as this can cause the weave to come undone. Simply trim the loose fibers with scissors. (fig. 7).

### Replacement Dirt Grip Soft Scrub Pads

For best cleaning results, we recommend replacing the Dirt Grip Soft Scrub Pads every 3 to 4 months following normal use. As with any fabric, dirt particles, grease, friction, and repeated washing can cause the fibers to break down, and you may notice an increase in the effort needed to push or pull the mop.

You can purchase replacement Dirt Grip Soft Scrub Pads and other accessories by visiting [sharkclean.co.uk](http://sharkclean.co.uk).

## TROUBLESHOOTING

PROBLEM	POSSIBLE REASONS & SOLUTIONS
<b>The steam mop isn't producing any steam.</b>	<p>The steam mop should be securely plugged into an electrical socket. Check your fuse or circuit breaker or try a different socket.</p> <p>Make sure the water tank is full, the unit is plugged in, and the mode button is illuminated.</p> <p>If the settings lights are off, try a different electrical socket.</p> <p>If the settings lights are blinking, press the mode button to select a steam setting.</p> <p>If the settings lights are illuminated steadily, wait 20 seconds for the unit to warm up.</p> <p>If after following the above steps the steam mop still does not produce any steam, contact Customer Service at <b>0800 862 0453</b> or visit <a href="http://sharkclean.co.uk">sharkclean.co.uk</a>.</p>
<b>The steam mop is producing intermittent steam.</b>	<p>This is normal. For more consistent steam, select the NORMAL setting.</p> <p>Also make sure the water tank is full.</p>
<b>I can't select a steam setting.</b>	<p>Make sure the steam mop is plugged in and the settings lights are flashing.</p> <p>If your steam mop is producing steam but the settings lights are off, call Customer Service at <b>0800 862 0453</b>.</p>
<b>Floors are cloudy, streaky, or spotty after steaming.</b>	<p>The Dirt Grip Soft Scrub Pads might be dirty. Install a clean set of pads. If you washed the Dirt Grip Soft Scrub Pads with powdered detergent, then they could be damaged and require replacement.</p> <p>Due to accumulated soap or grease residue, the floor may require several cleanings with the steam mop.</p> <p>A more stubborn case may require you to rinse the floor with a mix of one part vinegar and two parts water* (but <b>DO NOT</b> put any cleaning solution into the steam mop's water tank).</p> <p>*Please consult your flooring manufacturer's care and maintenance instructions before applying any cleaning products or solutions.</p>
<b>It's hard to push or pull the mop.</b>	<p>The mop might be hard to push or pull if the Dirt Grip Soft Scrub Pads aren't wet enough. It should get easier to move the mop across the floor after it's been running for a few minutes.</p> <p>Overly dirty pads could also make it harder to push or pull the mop. We recommend using clean pads.</p>
<b>Rotating discs are not turning or are wobbling.</b>	<p>The steam mop may be in the upright position. Tilt the handle down to use the mop.</p> <p>The Dirt Grip Soft Scrub Pads may not be centered. Turn the power OFF, unplug the steam mop, wait for a few moments to allow the pads to cool, then reinstall the Dirt Grip Soft Scrub Pads.</p>
<b>The steam mop is vibrating or wobbling.</b>	<p>The Dirt Grip Soft Scrub Pads are not centered on the rotating discs. Turn the power OFF and unplug the unit, and wait for the pads to cool. Follow the instructions in the Assembling Your Steam &amp; Scrub section to reinstall the pads.</p>
<b>The steam mop turns off on its own.</b>	<p>If your steam mop shuts off while in use, it likely needs to cool down. Perform the following steps before you restart cleaning:</p> <ol style="list-style-type: none"> <li>1. Turn the steam mop off, unplug it, and remove pads.</li> <li>2. Allow the unit to cool for a minimum of 30 minutes.</li> <li>3. Reinstall the pads. Plug in the steam mop, select a steam mode, and begin cleaning.</li> </ol>

PROBLEM	POSSIBLE REASONS & SOLUTIONS
Can I use the steam mop on carpets?	No, the steam mop is not designed for carpet cleaning.
What surfaces can I use the steam mop on?	The steam mop is designed for use on all sealed hard floor surfaces. We recommend consulting the use and care instructions from your floor manufacturer before using your Steam and Scrub Mop. <b>⚠ WARNING: DO NOT use on leather, wax-polished furniture, synthetic fabrics, velvet, or other delicate, steam-sensitive materials.</b> <b>NOTE:</b> On surfaces treated with wax and on some unwaxed floors, the sheen may be removed by the heat or steam action of the unit.
Can I put some-thing other than water in the water tank of the steam mop?	<b>DO NOT</b> add cleaning solutions, scented perfumes, oils, or any other chemicals to the water used in this appliance, as this will void your warranty and may damage the unit or make it unsafe for use. We recommend using distilled water in your Steam Mop.
I can't remove my wand from the main unit.	Before removing the wand, unplug the unit from the mains. Then locate the small hole at back of the unit, just under the cable wrap. Insert a screwdriver (or similar thin tool) into the hole and push the latch holding the handle in place. At the same time, lift the handle upwards to remove the wand.

When a consumer buys a product in the UK, they get the benefit of legal rights relating to the quality of the product (your "statutory rights"). You can enforce these rights against your retailer. However, at Shark® we are so confident about the quality of our products that we give the owner an additional manufacturer's guarantee of up to two years (1 year as standard plus 1 year when you register). These terms and conditions relate to our manufacturer's guarantee only – your statutory rights are unaffected.

The conditions below describe the prerequisites and scope of our guarantee. They do not affect your statutory rights or the obligations of your retailer and your contract with them.

#### Shark® Guarantees

A household appliance like a Steam and Scrub Mop constitutes a sizeable investment. Your new machine needs to work properly for as long as possible. The guarantee it comes with is an important consideration – and reflects how much confidence the manufacturer has in its product and manufacturing quality. Every Shark® machine comes with a free parts and labour guarantee. Our customer service helpline (0800 862 0453) is open from 9.00am to 6.00pm Monday – Friday. It's free to call, and you'll be put straight through to a Shark® representative. You'll also find online support at [www.sharkclean.co.uk](http://www.sharkclean.co.uk).

#### How do I register my extended Shark® guarantee?

If you have purchased your vacuum directly from [sharkclean.co.uk](http://sharkclean.co.uk) your extended guarantee is registered automatically. You can also register your guarantee online within 28 days of purchase.

- To register online, please visit [www.sharkclean.co.uk/register-guarantee](http://www.sharkclean.co.uk/register-guarantee).
- Keep a note of the date you purchased the machine.

#### IMPORTANT

- Both the 1 year standard and the extended 1 year guarantee will only cover your product from the date of purchase.
- Please keep your receipt at all times. Should you need to use your extended guarantee we will need your receipt to verify the information you have supplied to us is correct. The inability to produce a valid receipt may invalidate your guarantee.

#### What are the benefits of registering my free Shark® guarantee?

When you register your guarantee we'll have your details to hand if we ever need to get in touch. If you further agree to receive communications from us, you can also receive tips and advice on how to get the best out of your Shark Steam and Scrub Mop and hear the latest news about new Shark® technology and launches.

If you register your guarantee online, you'll get instant confirmation that we've received your details.

#### How long are new Shark machines guaranteed for?

Our confidence in our design and quality control means that your new Shark Steam and Scrub Mop is guaranteed for a total of up to two years (1 year plus an extended guarantee of 1 year).

#### What is covered by the free Shark® guarantee?

Repair or replacement of your Shark® machine (at Shark's discretion), including all parts and labour. A Shark® guarantee is in addition to your legal rights as a consumer.

#### What is not covered by the free Shark® guarantee?

- Normal wear and tear.
- Accidental damage or faults caused by negligent use or care, misuse, neglect, careless operation or handling of the Steam and Scrub Mop which is not in accordance with the Shark® Operating Manual supplied with your machine.
- Use of the Steam and Scrub Mop for anything other than normal domestic household purposes.
- Use of parts not assembled or installed in accordance with the operating instructions.
- Use of parts and accessories which are not Shark® Genuine Components.
- Faulty installation (except where installed by Shark®).
- Repairs or alterations carried out by parties other than Shark® or its agents.

#### Where can I buy genuine Shark® spares and accessories?

Shark® spares and accessories are developed by the same engineers who developed your Shark Steam and Scrub Mop. You'll find a full range of Shark® spares, replacement parts and accessories for all Shark® machines at [www.sharkclean.co.uk](http://www.sharkclean.co.uk).

Please remember that damage caused by the use of non-Shark spares may not be covered under your guarantee.







**PLEASE READ CAREFULLY AND KEEP FOR FUTURE REFERENCE.**

This Owner's Guide is designed to help you get a complete understanding of your new Shark® steam mop.

SharkNinja Europe Limited,  
1st/2nd Floor Building 3150,  
Thorpe Park, Century Way,  
Leeds, England, LS15 8ZB  
+44 (0)800 862 0453  
[www.sharkclean.co.uk](http://www.sharkclean.co.uk)

SharkNinja Germany GmbH,  
Rotfeder-Ring 9,  
60327 Frankfurt am Main,  
Germany  
[www.sharkclean.eu](http://www.sharkclean.eu)

Illustrations may differ from actual product. We are constantly striving to improve our products, therefore the specifications contained herein are subject to change without notice.

© 2024 SharkNinja Europe Limited.

SHARK is a registered trademark in the United Kingdom of SharkNinja Operating LLC.

DIRT GRIP and STEAM BLASTER are unregistered trademarks in the United Kingdom of SharkNinja Operating LLC.

S8201UK\_Series\_IB\_MP\_240617\_MVI