

# ***Shark*** **POWERDETECT**

**NEVERTOUCH**

**SELF-EMPTY**

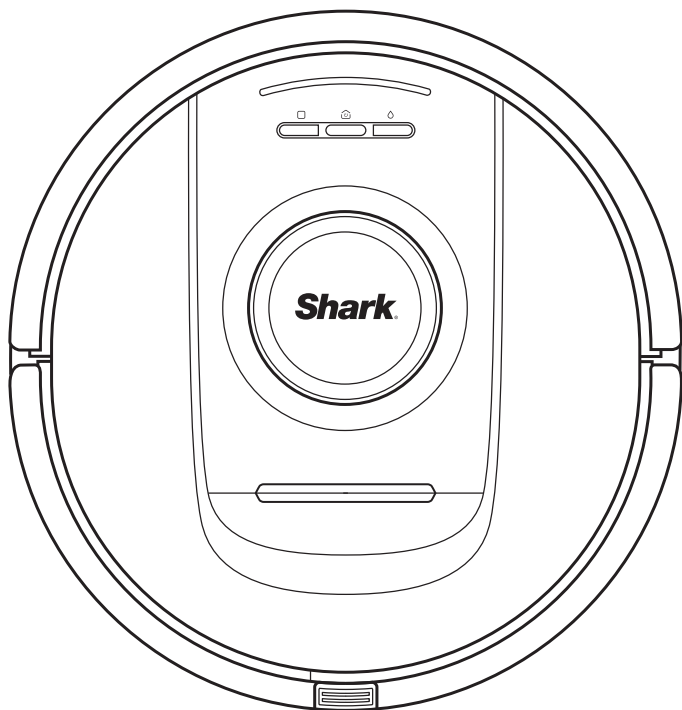

## **Robot Vacuum cleaner**

**RV2800YEUK SERIES,  
RV2800ZEUK SERIES,  
AV2800ZEUK SERIES**

**SHARKCLEAN APP**



# IMPORTANT SAFETY INSTRUCTIONS

PLEASE READ CAREFULLY BEFORE USE • FOR HOUSEHOLD USE ONLY

## ⚠ WARNING

To reduce the risk of fire, electric shock, injury, or property damage:

CHILDREN OR ANIMALS SHOULD NOT BE LEFT UNATTENDED IN ANY ROOMS THAT THE ROBOTIC VACUUM HAS ACCESS TO DURING CLEANING.

### LASER WARNING

THIS PRODUCT HAS A CLASS 1 LASER. ALWAYS TURN OFF THE POWER BEFORE LIFTING THE ROBOTIC VACUUM CLEANER OR PERFORMING ANY MAINTENANCE ON IT. DO NOT LOOK DIRECTLY INTO LASER.

IF THE CHARGING CABLE PLUG DOES NOT FIT FULLY INTO THE SOCKET, CONTACT A QUALIFIED ELECTRICIAN. DO NOT FORCE INTO SOCKET OR TRY TO MODIFY TO FIT.

### GENERAL WARNINGS

When using an electrical appliance, basic precautions should always be followed, including the following:

- This appliance consists of a Robot Floor Cleaner vacuum and charging dock with power supply. These components contain electrical connections, electrical wiring, and moving parts that potentially present risk to the user.
  - Before each use, carefully inspect all parts for any damage. If a part is damaged, discontinue use.
  - Use only identical replacement parts. See replacement accessories page of this booklet.
  - This Robot Floor Cleaner contains no serviceable parts.
  - Use only as described in this manual. DO NOT use Robot Floor Cleaner for any purpose other than those described in this manual.
  - Do not expose any parts of the robot floor cleaner to water or other liquids.
  - DO NOT put hands into any opening in the dock or robot.**
-  **USE WARNINGS**
- This product has a Class 1 Laser. Always turn off the power before lifting the robotic vacuum cleaner or performing any maintenance on it.
  - DO NOT** look directly into laser.
  - Always turn off the robotic vacuum cleaner before inserting or removing the filter or dustbin.
  - DO NOT** handle plug, charging dock, charging cable or Robot Floor Cleaner with wet hands. Cleaning and user maintenance must not be done by children without supervision
  - Children should **NOT** play with the appliance.
  - This appliance can be used by children aged from 8 years and above and persons with reduced physical, sensory, or mental capabilities or lack of experience and knowledge if they have been given supervision or instruction concerning use of the appliance in a safe way and understand the hazards involved.

- DO NOT** use the robot without the dustbin, filter in place.
- DO NOT** damage the charging cord:
  - DO NOT** pull or carry charging dock by the cord or use the cord as a handle.
  - DO NOT** unplug by pulling on cord. Grasp the plug, not the cord.
  - DO NOT** close a door on the cord, pull the cord around sharp corners, or leave the cord near heated surfaces.
  - The supply cord cannot be replaced. If the cord is damaged the appliance should be scrapped.
- DO NOT** put any objects into nozzle or accessory openings. **DO NOT** use with any opening blocked; keep free of dust, lint, hair, and anything that may reduce airflow.
- DO NOT** use if Robot Floor Cleaner airflow is restricted. If the air paths become blocked, turn the vacuum cleaner off and remove all obstructions before turning on the unit again.
- Keep nozzle and all vacuum openings away from hair, face, fingers, uncovered feet, or loose clothing.
- DO NOT** use if Robot Floor Cleaner is not working as it should, or has been dropped, damaged, left outdoors, or dropped into water.
- DO NOT** place vacuum cleaner on unstable surfaces.
- DO NOT** use to pick up:
  - Liquids.
  - Large objects.
  - Hard or sharp objects (glass, nails, screws, or coins).
  - Large quantities of dust (drywall dust, fireplace ash, or embers.)
  - DO NOT use as an attachment to power tools for dust collection.
  - Smoking or burning objects (hot coals, cigarette butts, or matches).
  - Flammable or combustible materials (lighter fluid, petrol, or kerosene).
  - Toxic materials (chlorine bleach, ammonia, or drain cleaner).

ENGLISH

- Toxic materials (high concentrations of chlorine bleach liquid, high concentrations of ammonia, or drain cleaning solution).
- DO NOT** use in the following areas:
    - Outdoor areas near fireplaces with unobstructed entrances
    - Spaces that are enclosed and may contain explosive or toxic fumes or vapors (lighter fluid, petrol, kerosene, paint, paint thinners, mothproofing substances, or flammable dust
    - In an area with a space heater
    - Near fireplaces with unobstructed entrances.
  - Remove all spilled or leaked liquid from the base or floor as it could lead to risk of electrical shock and/or floor damage.
  - Turn off the Robot Floor Cleaner before any adjustment, cleaning, maintenance or troubleshooting. Note: in the OFF (O) position, the robot still uses a small amount of power.
  - Allow all filters to air-dry completely before reinstalling them to prevent liquid from being drawn into electric parts.
  - DO NOT** modify or attempt to repair the robotic vacuum cleaner or the battery yourself, except as indicated in this Owner's Guide. **DO NOT** use the vacuum if it has been modified or damaged.
  - DO NOT** use any household cleaners (all-purpose cleaners, glass cleaners, bleach) on any of the polished high gloss surfaces on the docking station or robot vacuum cleaner as they contain chemicals that may damage these surfaces. Instead use a cloth dampened with water to gently clean.
  - To minimise the risk of the robot traveling beyond an unsafe boundary (stair or cliff edges, fireplaces, water hazards), establish these areas as no-go zones using the mapping feature in the SharkClean mobile app. Upon setting the boundary, run the vacuum and visually confirm that the settings effectively prevent the robot from passing beyond the set boundary. Adjust settings as necessary. For nonapp users, use a boundary to block off an unsafe boundary.
  - To prevent corrosion or damage to the product, only use the Shark branded floor cleaner in the water tank. Do not add too much cleaning fluid to prevent the robot from working improperly due to slipping. To avoid water tank deformation, do not add hot water in the tank, only room temperature water. If water marks remain on the water tank, wipe them clean before reinstallation.

### BATTERY USE

- The battery is the power source for the vacuum. Carefully read and follow all charging instructions.
  - To prevent unintentional starting, ensure the vacuum is powered off before picking it up or carrying it. **DO NOT** carry the appliance with your finger on the power switch.
  - Use only the SHARK charging dock and battery outlined in the table below. and use only battery RVBAT58002 (33V). Use of batteries or battery chargers other than those indicated may create a risk of fire.
  - Keep the battery away from all metal objects such as paper clips, coins, keys, nails, or screws. Shorting the battery terminals together increases the risk of fire or burns.
  - Under abusive conditions, liquids may be ejected from the battery. Avoid contact with this liquid, as it may cause irritation or burns. If contact occurs, flush with water. If liquid contacts eyes, seek medical help.
  - Robotic vacuum cleaner should not be stored, charged, or used at temperatures below 50°F (10°C) or above 104°F (40°C). Ensure the battery and vacuum have reached room temperature before charging or use. Exposing the robot or battery to temperatures outside of this range may damage the battery and increase the risk of fire.
  - DO NOT** expose the Robot Floor Cleaner or battery to fire or temperatures above 130°C (265°F) as it may cause explosion.
- ### NO-GO ZONES AND BOTBOUNDARY STRIPS
- DO NOT** put BotBoundary strips underneath carpet or rugs.
  - DO NOT** place BotBoundary strips on top of one another.
  - Always use no-go zones or Bot-Boundary strips around reflective flooring and surfaces.
  - No-go zones or BotBoundary strips should always be used near carpeted stairs.
  - DO NOT** use no-go zones or Bot-Boundary strips within 3 metres of the dock.
  - For your robot's cliff sensors to work properly, all runners, rugs, carpets, or small thresholds (like child gates) must be 20 centimetres from any stairs (or must be continuous and extend over the edge of the stairs). If a runner, rug, carpet, or small threshold that is less than 20 centimetres from the stairs cannot be moved, you must use a no-go zone or a BotBoundary strip to block off the stairs.

ENGLISH

Unit	Battery
SKU	RVBAT85002 (33V)

Unit	Dock
RV2800YEUK RV2800ZEUK AV2800ZEUKWH RV2800ZEUKWH	XDKRV2800WDEUK XDRV2800WDEUK XDOCK2800WDEUK XDOCKRV2800UK

## SAVE THESE INSTRUCTIONS

For the latest warnings and cautions, go to [www.sharkclean.co.uk/robothelp](http://www.sharkclean.co.uk/robothelp)

## WHAT'S INCLUDED

### 1. Anti-Odour Cartridge (1X)

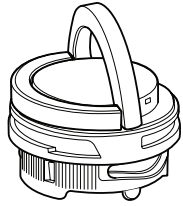

**Note:** Not included on all models

### 2. Side Brush (2X)

Side brush design may vary. Some models include a spare.

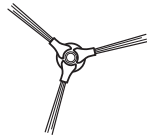

### 3. Robot (1X)

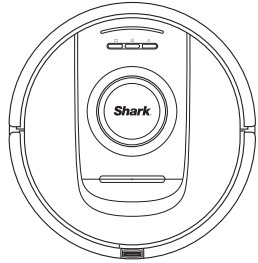

### 4. Antimicrobial Mopping Pads (3X)

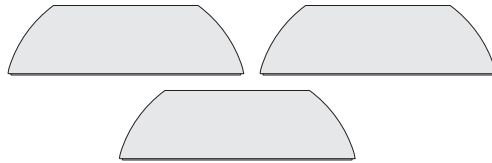

### 5. Ramp (1X)

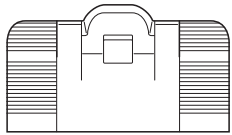

**OR**

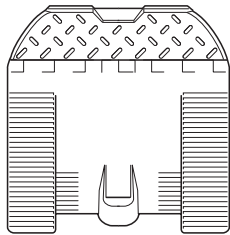

### 6. NeverTouch Base (1X)

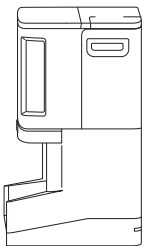

**OR**

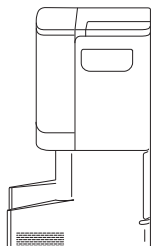

ENGLISH

## SET-UP YOUR SHARK ROBOT & NEVERTOUCH BASE

ENGLISH

### 1 Insert Odour Cartridge

**Note:** Not included on all models

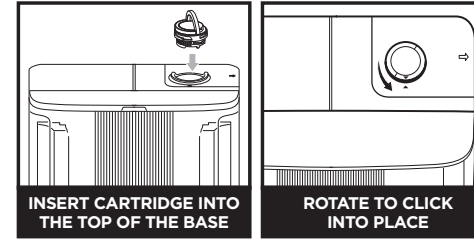

**Note:** Make sure the odour cartridge is installed in the base before using the robot.

### 2 Set Up Base

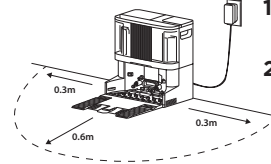

1. Remove all plastic wrap and foam.
2. Find a permanent location for the base in a central area with a strong Wi-Fi signal.
3. Ensure the base is not placed in area with direct sunlight.
4. Plug in the base. The LED will turn green when it is powered on.

### 3 Install Ramp On Base

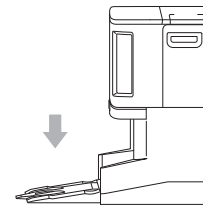

1. Align the flat side of the ramp with the bottom of the base.
2. **Lift the ramp slightly above the base, align, and press down until the ramp clicks into place.**
3. Leave at least 0.6m of hard floor space in front of the base, starting from the end of the ramp.

### 4 Fill The Clean Water Tank

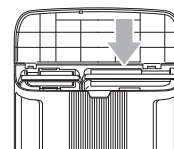

1. Lift the water tank off the front of the base.
2. **Fill the tank up to the MAX fill line with room-temperature water. Reinstall the tank.**

### 5 Attach a Side Brush to Bottom of Robot

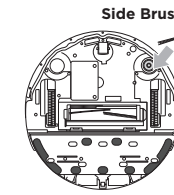

1. The side brush can be found inside the robot box.
2. Align the hole in the brush over the peg on the bottom of the robot, then press down on the brush until it clicks into place.

### 6 Slide Robot Onto Base

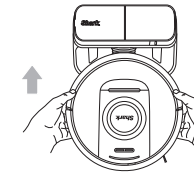

1. **Align the robot with the Shark logo upside down, then slide it up the ramp, onto the base.**
2. The LEDs on the base will turn green when the robot is charging.
3. After 10 to 15 seconds, the robot will begin to evacuate dust and debris into the base.

### 7 Download & Explore SharkClean App

or press the Dry icon  on your robot to start a dry clean.



#### App Features

- ✓ Mapping
- ✓ Scheduling
- ✓ No-Go Zones
- ✓ Cleaning Reports

GETTING TO KNOW YOUR SHARK ROBOT

ENGLISH

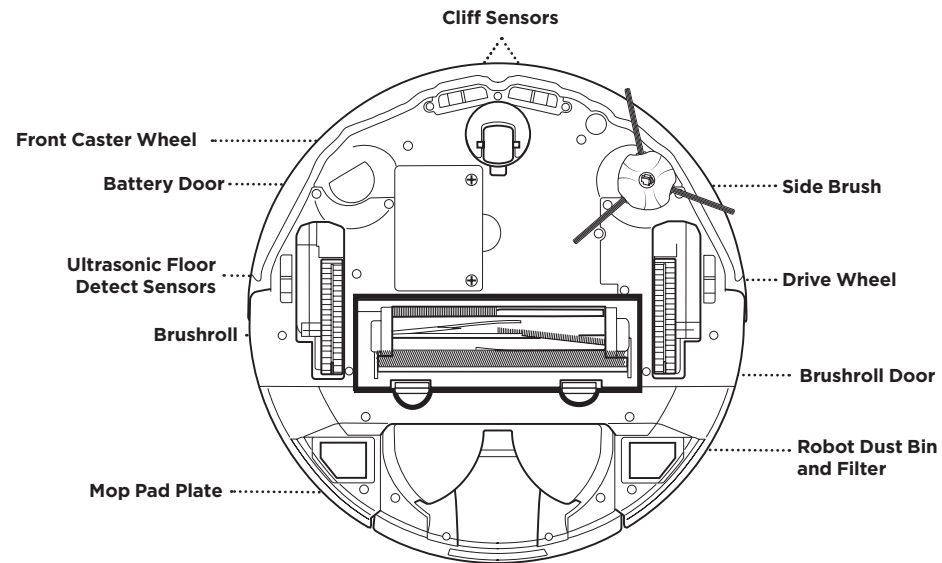
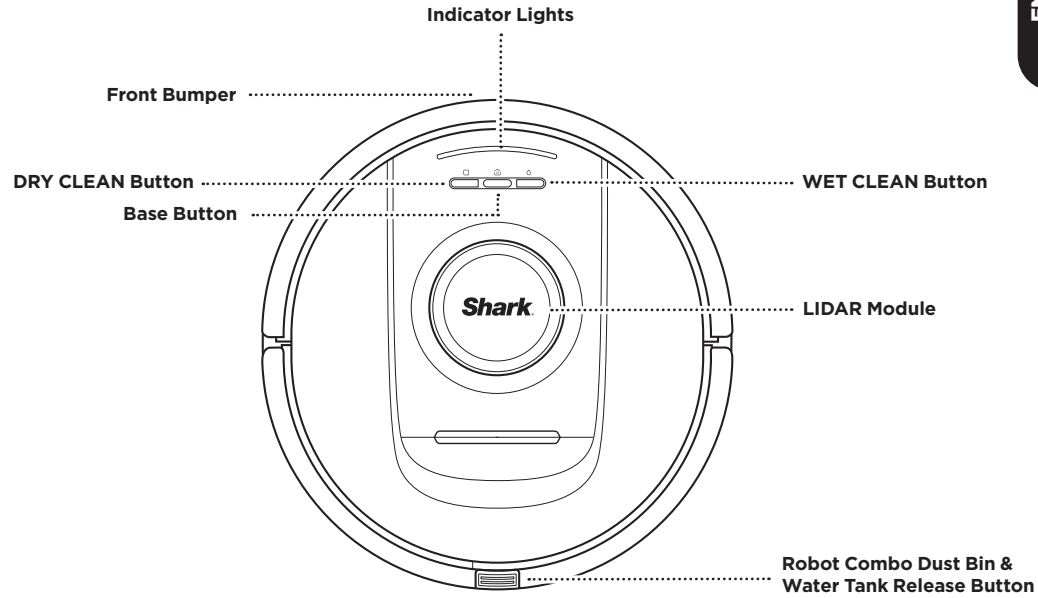

GETTING TO KNOW YOUR SHARK POWERDETECT NEVERTOUCH BASE

ENGLISH

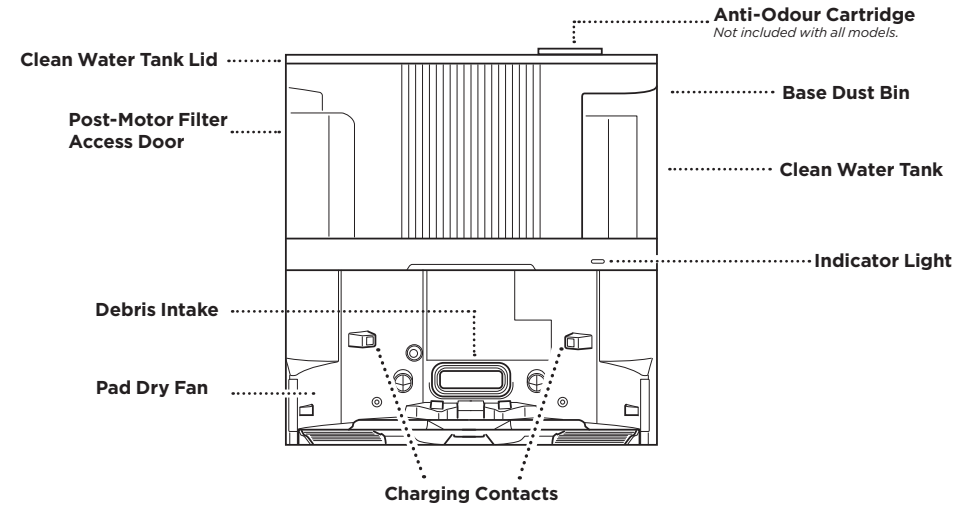

SELF-EMPTY BASE BACK

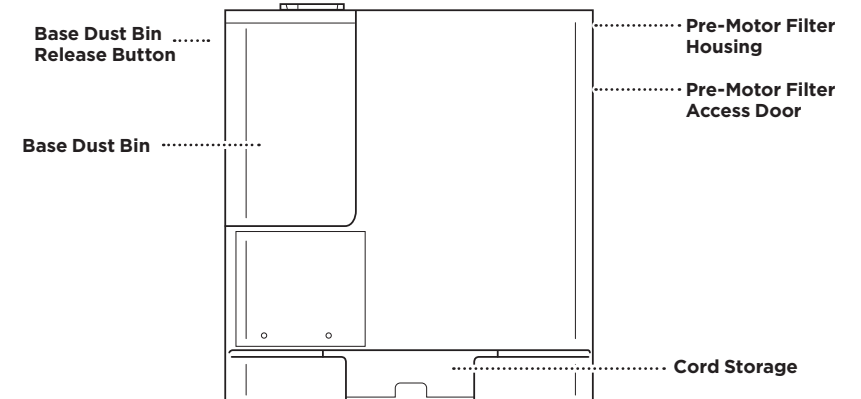

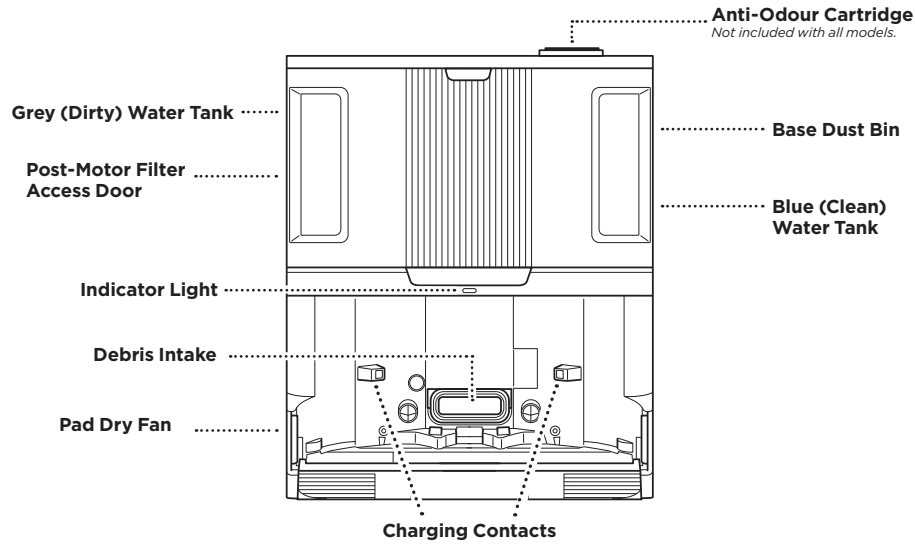

SELF-EMPTY BASE BACK

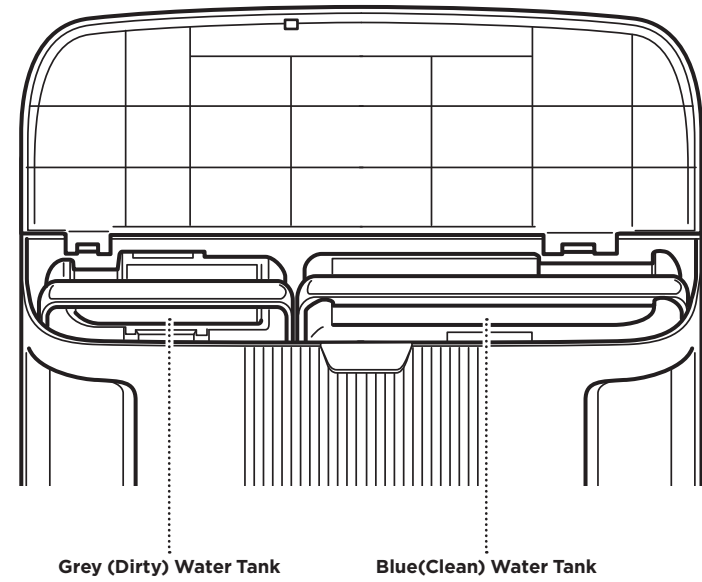
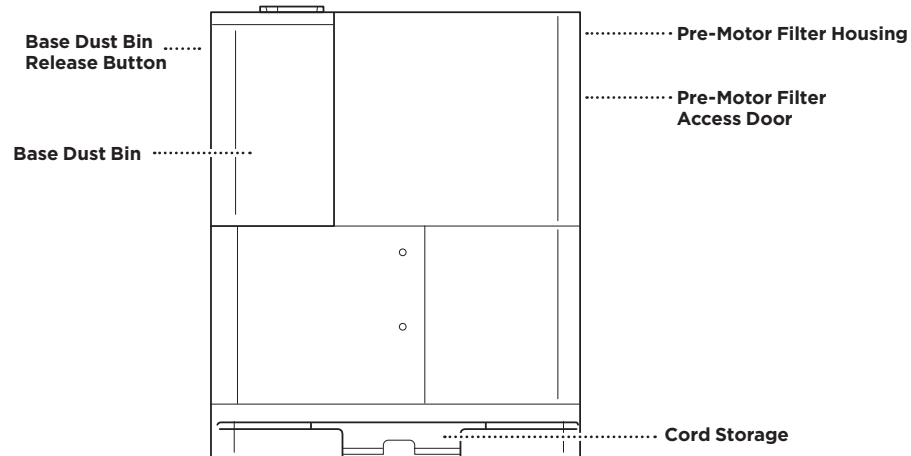

## LIVING WITH YOUR ROBOT

Please visit [sharkclean.co.uk/app](https://sharkclean.co.uk/app) or visit **Sharkclean** on **YouTube** for troubleshoot videos.

### DOORWAYS AND THRESHOLDS

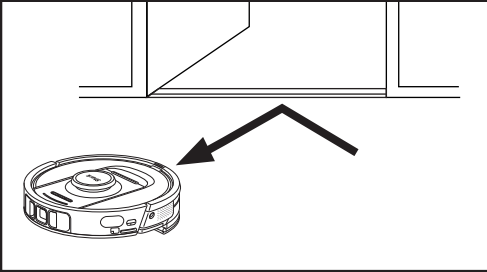

Your robot can easily climb over most thresholds, but if one is higher than 2.5cm, set up a no-go zone in the app to block it off.

### AVOID MOVING THE ROBOT OR SELF-EMPTY BASE

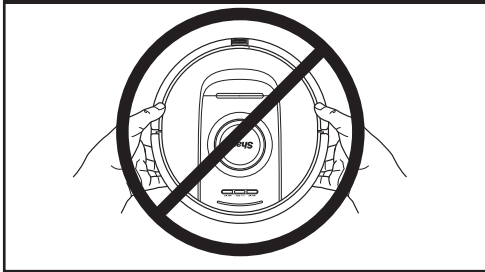

While your robot is cleaning, **DO NOT** pick it up and move it, or move the Self-Empty Base—this will impact the robot's ability to map your home. If the base is moved, you will need to remap your home.

### CAN'T CONNECT TO WI-FI?



#### NOTE:

Shark Robots use 2.4 GHz networks to connect. Typical home Wi-Fi networks support both 2.4 GHz and 5 GHz.

#### Restart your phone

- Turn off phone, wait a few minutes, then turn it back on and connect to Wi-Fi.

#### Reboot your robot

- Take robot off base and press and hold down the DOCK icon  on the robot for 5 to 7 seconds. Turn your robot back on by sliding it on the base.

#### Reboot your router

- Unplug the router power cable for 30 seconds, then plug it back in. Allow several minutes for your router to reboot completely.
- Then follow the steps outlined in the SharkClean app Wi-Fi setup instructions.

### START MOPPING MODE MANUALLY

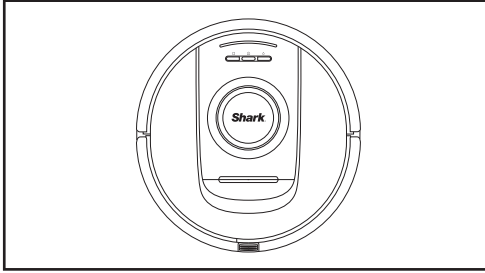

**If your POWERDETECT Base has enough water in the clean water tank and has a pad plate with mop pad attached, you can begin a wet clean by simply pressing WET icon  on the robot or by starting a wet clean in the app. For manual setup, please follow the below steps:**

#### Fill the robot water reservoir with water.

- Remove the combo dust bin & water tank from the robot. Lift the cap of the water reservoir and rotate it to the side. Fill water reservoir with water. Reinsert the water reservoir cap.

#### Attach a mop pad to the pad plate.

- If a mop pad is not currently attached to the pad plate, attach a mop pad by aligning the edge of the mop pad to the inlet of the pad plate. Slide the mop pad into this inlet, and when fully inserted, attach the mop pad to the pad plate.

#### Attach the pad plate and insert the robot dust bin.

- Attach the pad plate to the underside of the robot's combo dust bin & water tank by sliding it on from the rear of the robot dust bin. You will hear an audible CLICK when attached. With the mop pad side facing down, insert the robot combo dust bin & water tank into the robot.

**Press the WET icon  on the robot to begin mopping!**

## PREPARE YOUR HOME

Your robot uses an array of sensors to navigate around walls, furniture legs, and other obstacles while it cleans. To prevent the robot from entering areas you don't want it to, set up no-go zones in the app. For best results, prepare your home as indicated below, and schedule a daily cleaning to ensure all floor areas are regularly maintained.

**NOTE:** Scheduling is one of many features that can only be done in the app.



### OBSTRUCTIONS

Your Power Detect robot will avoid cords, but for the best coverage and cleaning, remove cords and objects smaller than 11.5 cm in height from floors.

To ensure a complete map of your home, open interior doors.

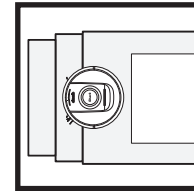

### STAIRS

Your robot's cliff sensors will prevent it from falling off ledges. For the cliff sensors to work properly in any mode, all runners, rugs, or carpets must be at least 20cm from any stairs, or must extend over the edge of the stairs.

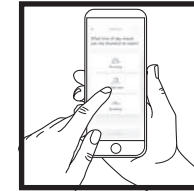

### SCHEDULING

Schedule whole-home vacuuming runs with the app.

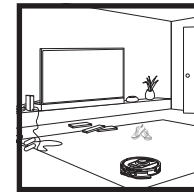

### CARPET MAPPING

Your robot will perform a dry, cleaning run while exploring and mapping your home. During this time, the robot will also automatically identify carpeted areas. If carpets are moved, you may need to have the robot re-explore your home.

## ROBOT BASE SET-UP

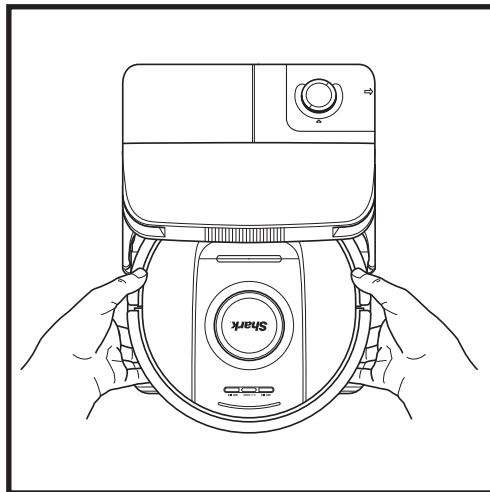
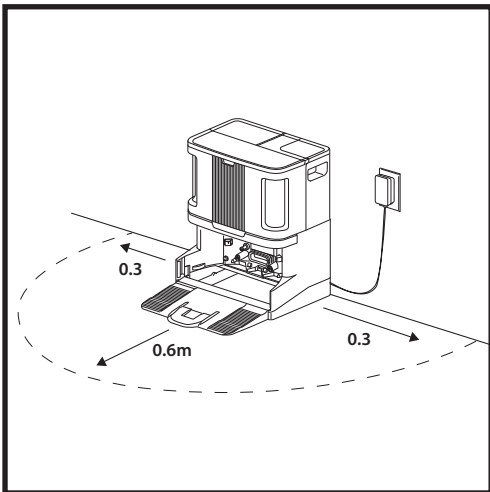

- Place the base with its back against a wall. Select a level surface on a **BARE FLOOR** in a central area with a **strong Wi-Fi signal**. Do not place it against baseboard heaters or other heating elements. Ensure the base is not placed in area with direct sunlight.
- Select a **permanent** location for the Robot Base because every time you relocate it, your robot will have to re-map your space. Remove any packaging from both the robot and the base.
- **Remove any objects** that are closer than 0.3m from either side of the base or closer than 0.6m from the front of the base. Ensure any carpeted floor is 1.2m away from the front of the base, or more.
- Plug in the base. The indicator light will **illuminate green when the base has power**.

## INSTALLING THE SIDE BRUSH

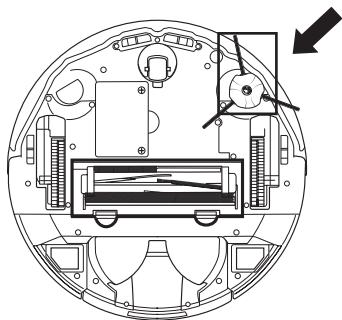

Attach the side brush to the post on the bottom of the robot.

**NOTE:** Side brush design may vary.

## INSTALLING THE ANTI-ODOUR CARTRIDGE

1. Open the packaged Odour Cartridge.
2. Flip up the handle on the odor dial.
3. Align the arrows.
4. Insert the assembly into the slot on the top right side of the base.
5. To lock the cartridge in-place, rotate it anti clockwise until it clicks in to place.
6. Continue to rotate the dial toward the high position to increase the intensity.

**NOTE:** The Anti-Odour Technology is not included with all models.

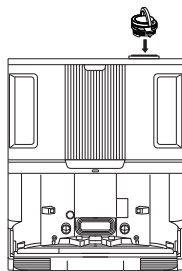

## ROBOT INDICATOR LIGHTS

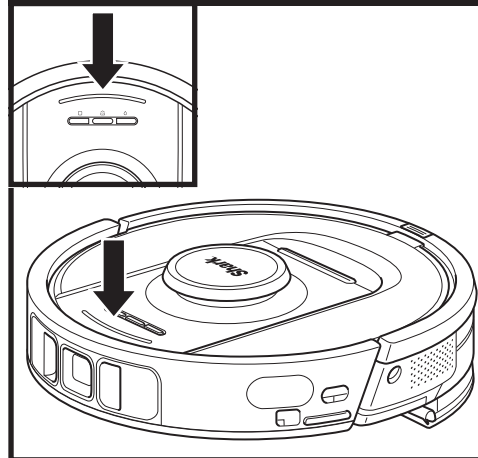

### Low Battery

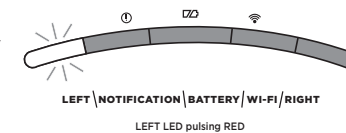

### Charging

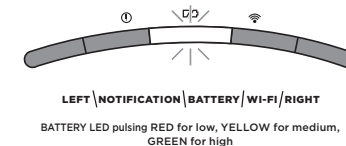

If your robot is low on battery power, the left LED light will pulse RED. Manually place the robot on the base to begin charging. When the robot is charging, the battery indicator light will pulse, based on the current battery charge level: RED for low, YELLOW for medium, GREEN for high.

When cleaning, the remaining battery level is indicated by the number of LED lights illuminated. At full battery power, 5 indicator lights will be illuminated. At 80% battery, 4 indicator lights will be illuminated, and so on.

## DIRTDETECT

DirtDetect detects hidden debris and automatically boosts power until no more dirt is detected. When the robot detects a mess, the lights on the robot will turn PURPLE to indicate that DirtDetect is enabled. The robot will deep-clean in a 3' x 3' pattern.

## ACTIVELIFT

When your robot activates ActiveLift to better navigate your home, your indicator lights will flash ORANGE to indicate that it has activated.

## CHARGING

**IMPORTANT:** Be sure to charge the robot completely before its first clean so that it can explore, map, and clean as much of your home as possible. It may take up to 4 hours\* to fully charge your robot.

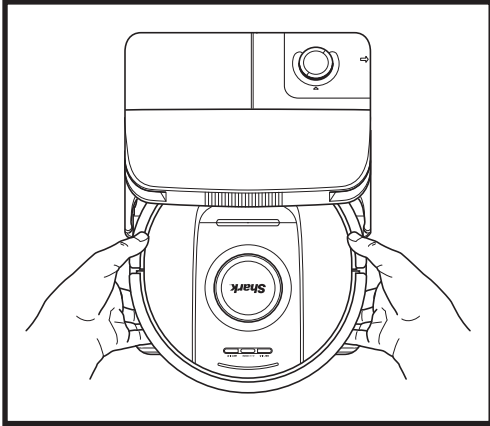

To **TURN THE ROBOT ON:** Slide the robot up the ramp on to the base or hold down DOCK icon  for 5 to 7 seconds, until the indicator lights turn on.

After 10 to 15 seconds, the robot will begin to evacuate dust and debris into the base.

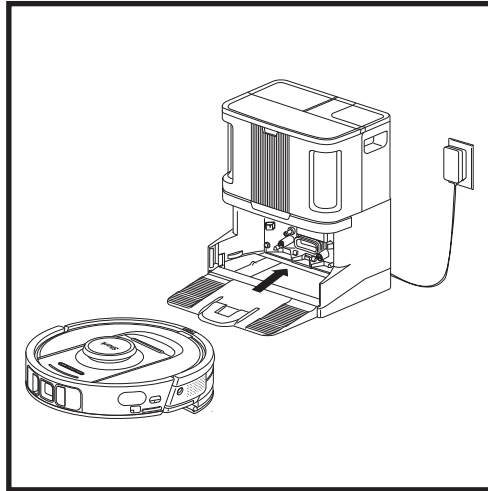

When the cleaning cycle is complete, or if the battery is running low, the robot will search for the Self-Empty Base. If the robot doesn't return to the base, its charge may have run out.

**NOTE:** When manually placing the robot on the base, make sure the Charging Contacts on the back end of the robot are touching the ones on the base.

**NOTE:** When picking up the robot, be careful not to place fingers between the bumper and the back of the robot.

\*Battery charge time may vary.

## ROBOT BUTTONS

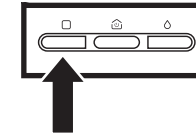
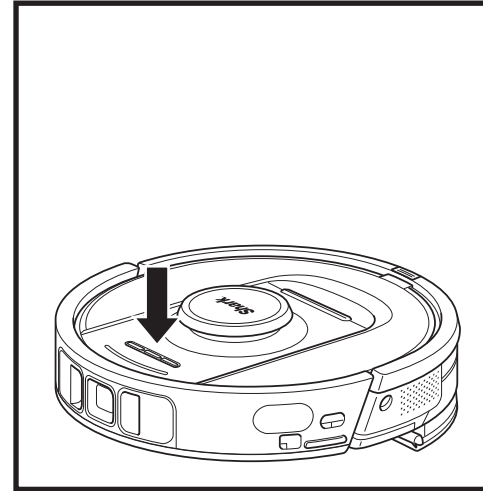

### DRY CLEAN BUTTON

If the robot is on the base, press the DRY icon on the robot  for a whole-home clean. Press again to pause the cleaning session.

For a 1.5m x 1.5m spot clean, press and hold the DRY icon  for 5-7 seconds.

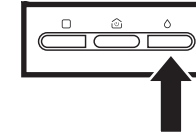

### WET CLEAN BUTTON

If the robot is on the base, press the WET icon  on the robot for a whole-home clean. Press again to pause the cleaning session.

For a 1.5m x 1.5m spot clean, press and hold the WET icon  for 5-7 seconds.

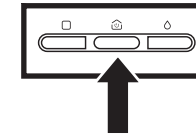

### DOCK BUTTON

To turn on/off your robot, press the DOCK icon  on the robot for 5-7 seconds.

Short press the DOCK icon  to send the robot back to the base.

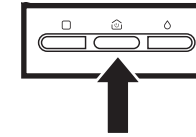

### RECHARGE & RESUME

Press and hold the DOCK icon  for 15 seconds to turn Recharge & Resume ON or OFF.

The Recharge & Resume function is turned ON by default. The robot will run until it reaches low battery. If its cleaning mission is not complete at that time, it will return to the base, recharge, and then pick up where it left off.

## USING THE SHARK POWERDETECT

Please visit [sharkclean.co.uk/app](https://sharkclean.co.uk/app) or visit **SharkClean** on **YouTube** for troubleshooting videos.

## USING THE SHARKCLEAN APP AND VOICE CONTROLS

Get the most out of your Shark® robot vacuum with these app features:

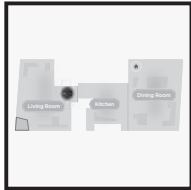

- **Recharge and Resume**  
The robot will return to the Self-Empty Base, recharge, and can pick up where it left off.
- **Vacuum + Mop:** Full home cleaning. Dry cleaning of carpeted areas followed by mopping of bare floors.
- **No-Go Zones**  
Use the no-go zones in the app to keep your robot out of the areas you would like it to avoid.

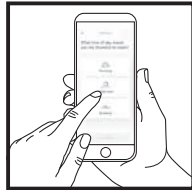

- **Scheduling**  
Set up whole-home cleanings for any time, any day.
- **Control From Anywhere**  
Wherever you are, you're in control of your robot.
- **Cleaning Reports**  
Each time your robot cleans, your app will generate a cleaning report.

Search for **SharkClean** in the app store and download the app to your smartphone..



### SETTING UP VOICE CONTROL WITH THE GOOGLE ASSISTANT OR AMAZON ALEXA

Visit [sharkclean.co.uk/app](https://sharkclean.co.uk/app) for setup instructions, which include how to enable Shark Skill for Amazon Alexa and using with Google Assistant.

#### Google Assistant:

- Hey Google, start vacuuming.
- Hey Google, tell (robot name) to vacuum.
- Hey Google, pause vacuuming.
- Hey Google, tell (robot name) to go home.

#### Amazon Alexa:

- Alexa, ask Shark to start vacuuming/cleaning the (room name).
- Alexa, start/stop the vacuum.
- Alexa, send the vacuum to Self-Empty Base.

## WI-FI TROUBLESHOOTING

To use the app, your phone must be connected to a 2.4GHz network. The app will only work on a 2.4GHz network.

- Typical home Wi-Fi networks support both 2.4GHz and 5GHz.
- Do not use a VPN or a proxy server.
- Make sure Wi-Fi isolation is turned off on the router.
- Questions? Steps if You're Stuck: Having trouble connecting to your robot? For how-to videos, FAQs, troubleshooting, and tips & tricks visit: [sharkclean.co.uk](https://sharkclean.co.uk)

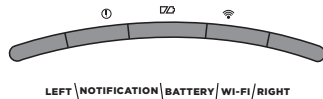

LEFT | NOTIFICATION | BATTERY | WI-FI | RIGHT

ERROR CODE	PROBLEM
LEFT LED (YELLOW) flashing	Wrong password for Wi-Fi
LEFT LED (YELLOW) + RIGHT LED (YELLOW) flashing	SSID cannot be found, try connecting again
NOTIFICATION LED (RED) + WIFI LED (RED) flashing	Cannot connect to Wi-Fi

## WI-FI TROUBLESHOOTING

### How do I use my robot with Amazon Alexa?

Open the Amazon Alexa app, go to the menu and select Skills. Or go to the Alexa Skills store on the Amazon website. Search for "Shark Skill". Select the Shark Skill to open the detail page, then select the Enable Skill option. Once enabled, you can ask Alexa to control your robot (i.e., "Alexa, tell Shark to start cleaning").



### How do I set up my robot with the Google Assistant on an Apple device?

**1.** Download, open, and sign into the Google Assistant app. **2.** Select the "Explore" icon. Search for "Shark" and select "Try it." **3.** To allow Google to link to your SharkClean account, sign into your SharkClean account. This is the same account you used when setting up your Shark robot in the SharkClean app. Select "Authorize" to link your SharkClean account to the Google Assistant. Congratulations! The Google Assistant now works with your Shark robot. To send your robot into action, use the voice command, "Google, tell Shark to start cleaning."

### How do I set up my robot with the Google Assistant on Android?

**1.** Download, open, and sign into the Google Assistant app. **2.** Select the "Explore" icon. Search for "Shark" and select "Link." **3.** Sign into your SharkClean account. This is the same account you used when setting up your Shark robot in the SharkClean app. Congratulations! The Google Assistant now works with your Shark robot. To send your robot into action, use the voice command, "Google, tell Shark to start cleaning."

### What should I do if my Wi-Fi randomly disconnects?

Turn OFF the robot, by pressing and holding the DOCK button  for 5-7 seconds. Wait 10 seconds, then turn the robot power back on by pressing and holding the DOCK button  for 5-7 seconds. Turn off your phone. Wait 30 seconds, then turn your phone back on. Open Wi-Fi settings on your phone, find the Shark network, and select Forget Network. Reopen SharkClean app and retry the connection process. It is normal for your robot to temporarily lose connectivity when it goes under furniture or moves far from your router. Your Shark® robot will automatically reconnect to Wi-Fi. If the robot does not reconnect, power it off, wait 10 seconds, power the robot back on, and place it back on the base.

### What should I do if I verified a wireless network password that is incorrect?

Close the app, then reopen it. Make sure that you entered the correct Wi-Fi network password this time. In your phone's network settings, choose your home 2.4 GHz network, and select Forget. Reconnect to your home network. Make sure to use the correct password. If you were able to connect to your home network, proceed to the app setup process. We recommend that you use the eye icon when entering your password to make sure it is correct. Turn off your router and wait 30 seconds. Turn your router back on. Check to make sure your 2.4 GHz network is visible in your phone settings. Turn off the robot, then wait 10 seconds. Turn the robot back on and wait for the voice prompt. Hard-close the app and restart the connection process on the robot. If you cannot locate your Wi-Fi password, please contact your Internet service provider.

### What should I do if my username or password is invalid?

We recommend you select the eye icon next to the password entry to verify you are entering your password correctly. Select the 'Forgot Password' option on the sign-in page. The automated system will email you a link to reset your password. If you do not see an email, search your inbox and spam folder for emails from myshark-ninja@sharkninja.com. You can use the "Resend code" option to send the email again.

### What should I do if there is an issue resetting password (did not receive the email or token was invalid)?

Select the 'Forgot Password' option on the sign-in page. The automated system will email you a link to reset your password. If you do not see an email, search your inbox and spam folder for emails from mysharkninja@sharkninja.com. You can use the "Resend code" option to send the email again.

## WI-FI TROUBLESHOOTING

### What should I do if my Shark® robot won't connect to Wi-Fi or loses Wi-Fi connectivity?

If you are an iOS user and recently upgraded to iOS 14, you need to enable local network access on your phone for the SharkClean app. Please take the following steps to enable.

- Go to your phone settings --> Select Privacy--> Select Local Network --> Toggle SharkClean on, then try connecting again.

#### Other troubleshooting steps:

- Ensure your phone is connected to your home Wi-Fi network before trying to connect your robot.
- Typical home Wi-Fi networks support both 2.4 GHz and 5 GHz. Ensure you are connected to a 2.4 GHz network when you enter your username and password.
- Ensure your robot is turned on and you hear an audio prompt. Do not use a VPN or a proxy server. Ensure Wi-Fi isolation is turned off on the router.

**Note:** Shark® robot vacuums cannot connect to 5GHz band.

#### There may be instances where your Shark robot loses connectivity while operating, due to a weak Wi-Fi signal, or entering a zone that blocks Wi-Fi. In such cases:

- Turn off the robot.
- Wait 10 seconds, then turn the power back on and wait for the voice prompt.
- Power off your phone, wait 30 seconds, and power back on.
- Open Wi-Fi settings on your phone, find the Shark network, then select Forget Network.
- Reopen the SharkClean app and retry the connection process.

#### It is normal for your robot to temporarily lose connectivity when it goes under furniture or moves far from your router. Your Shark robot will automatically reconnect to Wi-Fi.

- If the robot does not reconnect on its own, remove the unit from the base.
- Power the robot off, wait 10 seconds, and place it back on the base.

ENGLISH

## USING THE SHARK POWERDETECT

### 3D SENSOR AND AI LASER NAVIGATION

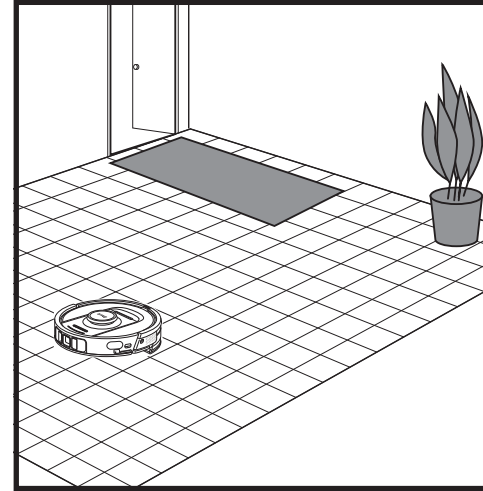

After setup is complete, your robot will conduct an **Explore Run** to create an initial map of your home. The robot will travel from room to room to identify walls, furniture, carpets, and other obstacles as it cleans. The robot will complete a full dry clean as it creates the map of your home.

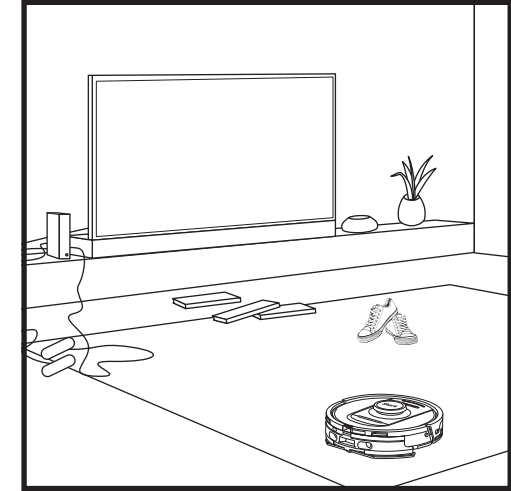

The robot's object detection technology helps it navigate around obstacles taller than 11.5cm in height, as well as some common household objects like cords, cables, shoes, and clothes.



ENGLISH

## MANUAL CLEANING MODE

To manually start a dry or wet clean, press the DRY  or WET  icons on the robot or on the mobile app, respectively. To immediately send the robot back to the base, press the DOCK icon .

## VACUUM + MOP

Vacuum + Mop mode enables a whole home, wet and dry clean with zero manual interaction required. A Vacuum + Mop can be activated within the SharkClean app, or manually without the app.

- Vacuum + Mop with the SharkClean app: To start a Vacuum + Mop with the app and your robot will begin by vacuuming the carpets then resume mopping all bare floor surfaces.
- To enter Vacuum + Mop manually: simultaneously press and hold the DRY  and WET  icons on the robot for 3 or more seconds.

Vacuum + Mop can only be used for a whole home clean. Vacuum + Mop is not compatible with cleaning by room.

**TIP:** Be sure to charge the robot completely before its first clean so that it can explore, map, and clean as much of your home as possible. It may take up to 4 hours\* to fully charge your robot.

**NOTE:** Avoid moving the base. If it is relocated, the robot may not be able to find its way back to the base, and you will need to re-map your home. If the robot is relocated while in use, it may not be able to follow its intelligent cleaning path or find its way back to the base.

\*Battery charge time may vary.

## MAINTENANCE OVERVIEW

NOTE: To order replacement visit [sharkclean.co.uk](http://sharkclean.co.uk).

Component	Frequency	Replacement Part(s)
<b>Base Maintenance</b>		
<b>BEFORE PERFORMING ANY MAINTENANCE, TURN OFF POWER TO YOUR BASE BY UNPLUGGING IT FROM ITS POWER SOURCE.</b>		
<b>Base Dust Bin</b> <b>NOTE:</b> Capacity varies depending on the model.	Every 30 or 60 days, depending on the model	4941K2800WDEUK 4943K2800WDEUK 5016K2800WDEUK
<b>Base Pre-Motor Filter</b>	Every 30 days, or as needed	XPRFRV2800EEU
<b>Base Post-Motor Filter (HEPA)</b>	Every 6 months, or as needed	XPRFRV2800EEU
<b>Base Ramp</b>	Every 3 months, or as needed	4948K2800WDEUK 4940K2800WDEUK
<b>Anti-Odour Technology</b> <b>NOTE:</b> Anti-Odour Technology is not included with all models.	Every 6 months, or as needed	5344Z3000EUKT
<b>Blue (Clean) Water Tank</b>	Every 30 days, or before every refill	44K2800WDEUK 4945K2800WDEUK
<b>Grey (Dirty) Water Tank</b> <b>NOTE:</b> Not all models include a grey water tank.	Every 30 days, or as needed	4946K2800WDEUK

ENGLISH

## MAINTENANCE OVERVIEW

Component	Frequency	Replacement Part(s)
<b>Robot Maintenance</b>		
<b>BEFORE PERFORMING ANY MAINTENANCE, POWER OFF YOUR ROBOT. TO DO THIS, PRESS AND HOLD THE DOCK ICON ON THE ROBOT FOR 5-7 SECONDS. REMOVE THE ROBOT WATER TANK.</b>		
<b>Mop Pad</b> <b>NOTE:</b> After a wet clean mission, the NEVERTOUCH PRO base will automatically wash the robot mop pad. Regardless, it is recommended to clean the mop pad in the washing machine or replace the pad every three months or as needed.	Every 3 months, or as needed	939K2800WDEUK 4938K2800WDEUK
<b>Sensors and Charging Contacts</b>	Every 30 days, or as needed	N/A
<b>Side Brush</b>	As needed	58MMSB2PKEUK

ENGLISH

Sensor Name	Functional Description
<b>Cliff Sensor</b>	Cliff sensors monitor the cliff to avoid falling by way of infrared ranging. If there is a downward stair in front (e.g. the height of the white ground is greater than 50mm, or the black ground is greater than 30mm), the reading value of the sensor exceeds the preset value, then robot stop moving forward.
<b>Lidar Sensor</b>	Lidar sensor help robot map through laser ranging. Detective distance is 8m.
<b>3D Sensor</b>	With 2 line-lasers and an IR camera, the 3D sensor scans the objects to identify the image through algorithms. FOV: H=100°, V=78.7°.
<b>Wall Follow Sensor</b>	Wall follow sensor detects the distance between the objects and the left side of the robot by the TOF ranging. Detective distance is 30mm.

## MAINTENANCE

### MAINTAINING THE BASE DUST BIN

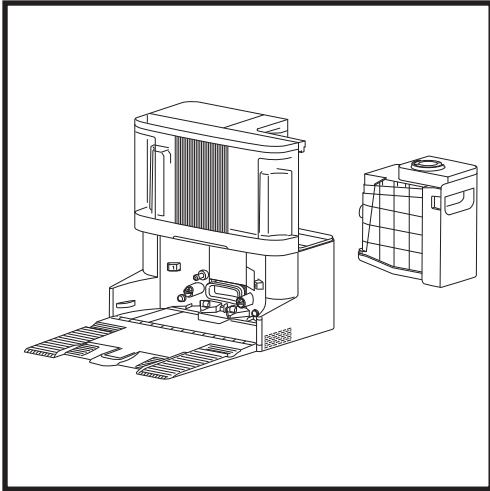

Depending on the size of the base, empty the base dust bin every 30 to 60 days or as needed.

To detach the bin, press the **Dust Bin Release** button on the back right side of the base, then slide out the bin.

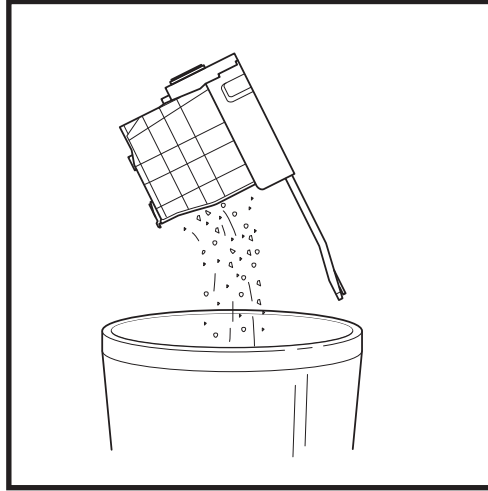

To empty the bin, hold it over the trash, then press the dustbin release button to empty. The bin lid will open, releasing dust and debris. Lightly tap the dust bin against the inside of the trash receptacle to knock off any remaining debris. Reinstall the bin by sliding it into the slot in the base until it clicks into place.

### CLEANING AND REPLACING THE BASE FILTERS

Regularly clean the filters to keep your vacuum's suction power optimal. Replace filters every 6-12 months or as needed.

**IMPORTANT: DO NOT** use soap when cleaning the filters.

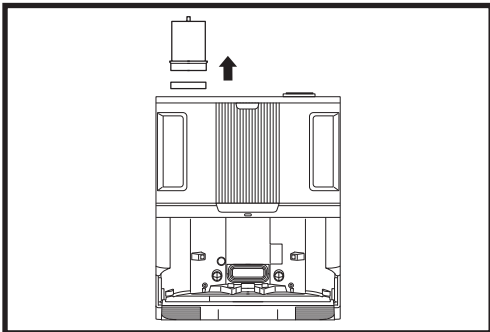

#### CLEAN PRE-MOTOR FILTERS ONCE A MONTH

To open the filter housing lid, hold the top left edge of the base and pull up on the lid. With the lid open, remove the foam filter by the top handle, then lift out the felt filter underneath. Tap the filters clean over the trash, then **rinse with cold water ONLY**, as soap may damage them. Allow filters to air-dry completely for at least 48 hours before reinstalling to prevent liquid from being drawn into electrical parts. The filters must be installed correctly for the base to work properly. Reinsert the felt filter first, then the foam filter.

#### CLEAN POST-MOTOR FILTER EVERY SIX MONTHS

Press the button at the top of the Filter Door, then tilt the door and lift it off. Remove the Post-Motor Filter from the base by pulling the tab down.

Tap the filters clean over the trash. **DO NOT use water or soap to clean this filter as this will cause damage.** More frequent cleaning may be required with heavy use.

Reinstall the filter to the base by inserting the bottom half first. Push filter until it clicks into place. Then reinstall the filter door.

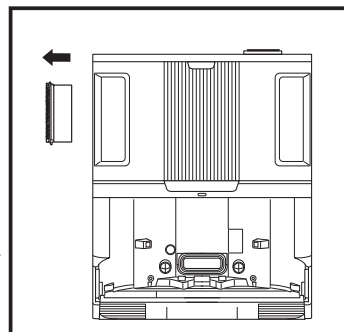

ENGLISH

## MAINTENANCE

**CAUTION:** Turn off power before performing any maintenance. To turn the base power off, simply unplug it from the electrical outlet.

### CLEANING THE PAD PLATE TRAY

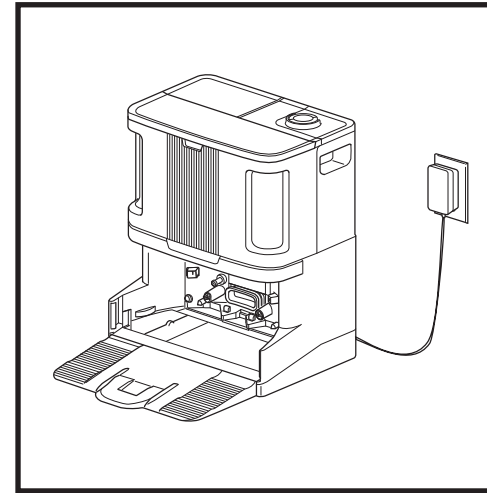

With the ramp removed, you can access the pad plate tray.

To clean the pad plate tray, wipe it down with a damp microfiber cloth.

For base models with pad wash: carefully remove the grey water mesh on the left-hand side and clear any debris, then reinstall.

Allow the tray to completely dry for at least 48 hours before reinstalling the ramp and the robot.

### ANTI-ODOUR TECHNOLOGY

It is recommended to replace the Anti-Odour Technology cartridge every 6 months, or as needed.

1. Flip up the handle and rotate the dial anti-clockwise until the two arrows are aligned. Pull the handle to remove the dial from the base.

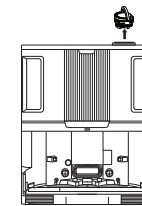

2. Rotate the cartridge anti-clockwise in the dial housing and pull out the cartridge to remove it.

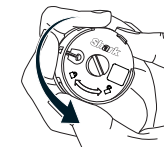

3. Remove the new odour cartridge from the sealed packaging. To maintain the life of the cartridge, keep it in the sealed packaging until you are ready to install it.



4. Align the yellow arrow on the side of the cartridge with the yellow arrow on the side of the dial cover, then insert the cartridge into the dial. Rotate the cartridge clockwise to lock it in place.

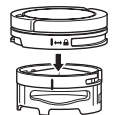

5. Align the arrow on the dial cover with the arrow on the base, then reinsert the dial into the base. Rotate the dial anti-clockwise until it clicks into an intensity setting to engage. Rotate further to change the intensity setting.

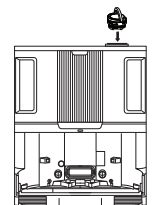

6. Dispose of the old cartridge by dropping it into the trash.



**NOTE:** The Anti-Odour Technology is not included in all models.

ENGLISH

## MAINTENANCE

### MANUAL ROBOT INTERACTIONS

**CAUTION:** Turn off power and remove the robot's water tank before performing any maintenance. To turn the robot power off, press and hold the DOCK icon  on the robot for 5-7 seconds.

**NOTE:** With the self-emptying robot, these actions will not be required for regular maintenance.

### FILLING THE ROBOT WATER TANK

Though the base will automatically refill the robot water tank, you can also access and fill it manually if needed.

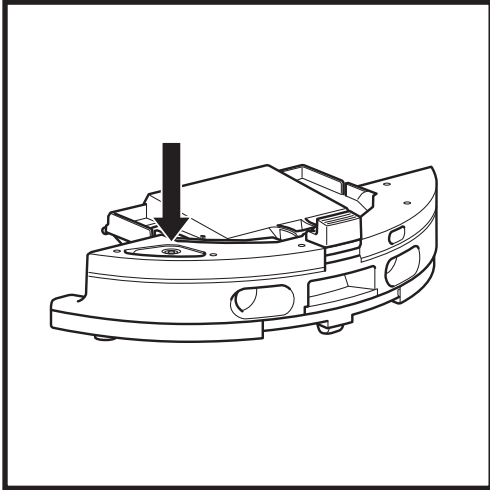

1. To open the robot water tank, pull the rubber stop from its sealed location to open the port. Fill with water and then secure the rubber seal back in place.
2. After filling and sealing the robot water tank, be sure to **wipe the robot evacuation port dry** with a microfiber cloth.

### PAD PLATE REMOVAL & REINSTALLATION

Though the base will automatically remove and reinstall the pad plate, you can also remove it manually if needed.

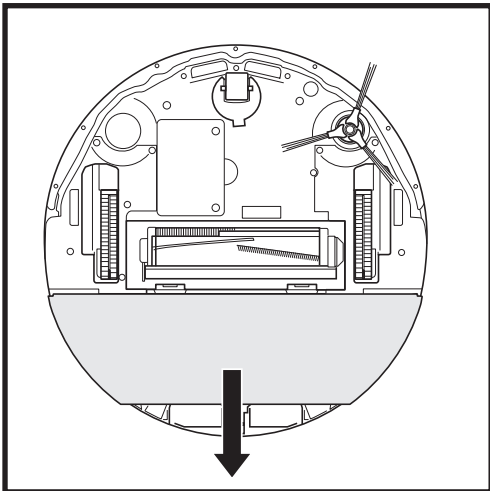

1. To remove the pad plate, use two fingers to gently pull the pad plate off the bottom of the robot.
2. To reattach the pad plate, slide it until you hear it click into place.

**NOTE:** DO NOT to remove the pad plate directly from the base.

If the pad plate is on the base, slide the robot up the ramp to install, send the robot for a wet clean, pause the robot, and then remove the pad plate from the robot following the steps above.

## MAINTENANCE

### EMPTYING THE ROBOT DUST BIN

**CAUTION:** Turn off power and remove the robot's water tank before performing any maintenance. To turn the robot power off, press and hold the DOCK icon  on the robot for 5-7 seconds.

**NOTE:** With the self-emptying robot, these actions will not be required for regular maintenance.

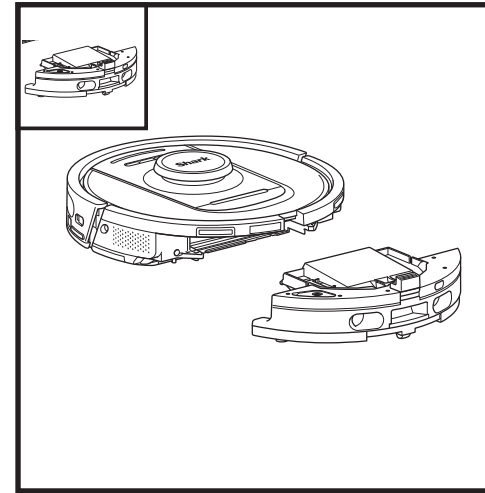

Press the **Dust Bin Release Button** and slide the dust bin out from the robot.

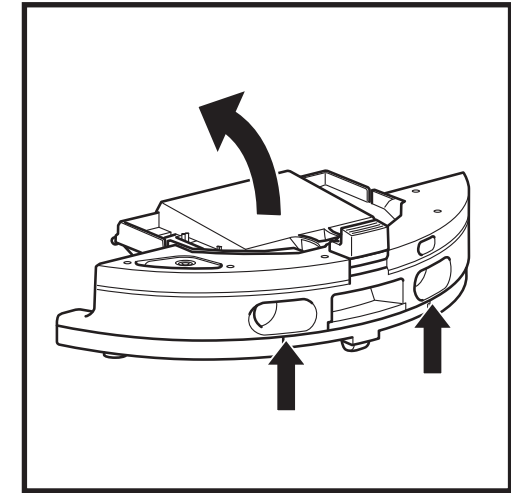

To open the robot dust bin lid, pinch and lift up using the finger slots.

**Regularly clean the filters to keep your vacuum's suction power optimal. Replace filters every 6-12 months or as needed.**

**IMPORTANT: DO NOT** use soap when cleaning the filters.

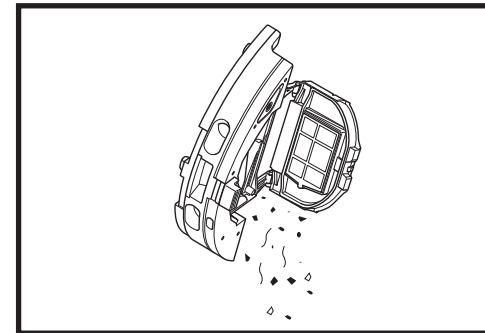

Empty debris and dust into the trash. If desired, you may use a dry cloth to wipe the interior of the dust bin.

Remove the filter out of the dust bin using the tabs. Lightly tap the filter over the trash to remove debris every time you empty the dust bin. Reinsert the filter into the dust bin, then slide the dust bin back into the robot until it clicks into place.

**NOTE:** After emptying the dust bin, reinsert the dust bin completely, until it clicks into place on the robot.

## MAINTENANCE

### MAINTAINING THE WATER TANK(S)

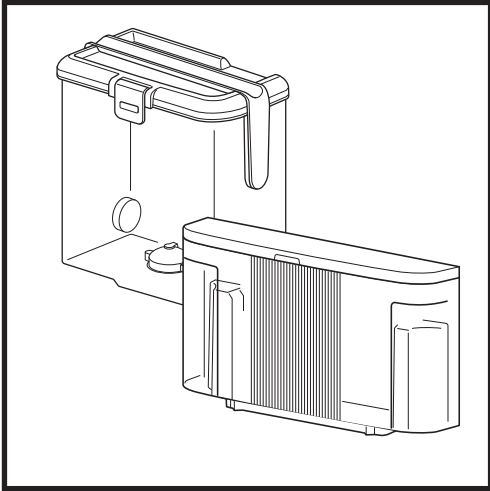

1. It is recommended to clean the base clean water tank before every refill, or once every 30 days.
2. To do so, wash the clean water tank with warm water and soap. Rinse thoroughly.
3. Allow the tank to air-dry for at least 48 hours before reinstalling.

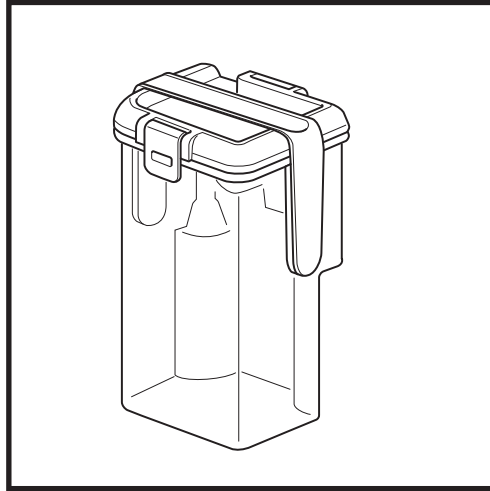

1. The NEVERTOUCH PRO base includes a grey water tank that collects and store dirty water after pad wash.
2. This tank should be emptied and cleaned as needed, or once every 30 days.
3. To do so, open the tank lid and pour out the dirty water. Fill the tank with clean water and some soap, close the lid, lock it, and shake.
4. Pour out the dirty water and rinse thoroughly.
5. Allow the tank to air-dry for at least 48 hours before reinstalling.

**DO NOT** reinstall any water tanks filled with warm water. Always use room-temperature water to fill the water tank before use.

**DO NOT** move the base while the water tank is full.

### CLEANING THE BASE RAMP

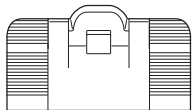

OR

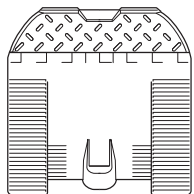

It is recommended to clean the base ramp every three months or as needed.

#### TO DO SO:

1. Carefully lift the ramp up and away from the base.
2. Use a damp cloth to wipe down the ramp. Allow the ramp to air-dry for at least 48 hours before reinstalling.
3. Once dry, lift the ramp slightly above the base, align, and press down until the ramp clicks into place.

## MAINTENANCE

**CAUTION:** Turn off power and remove the robot's water tank before performing any maintenance. To turn the robot power off, press and hold the DOCK icon  on the robot for 5-7 seconds.

### CLEANING AND REPLACING THE MOP PAD

After a wet clean mission, the NEVERTOUCH PRO base will automatically wash the robot mop pad. Regardless, it is recommended to clean the mop pad in the washing machine or replace the pad every three months or as needed. To do so:

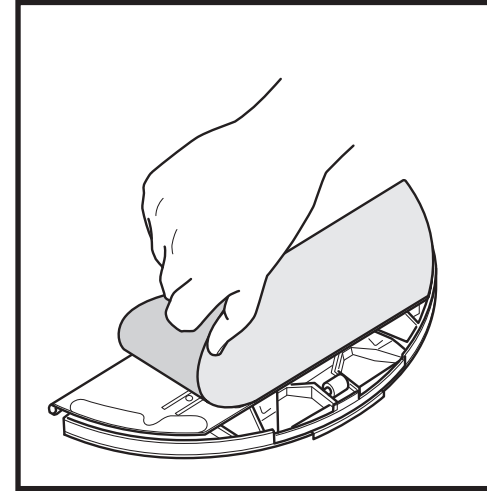

1. Carefully pull the pad away from the pad plate.

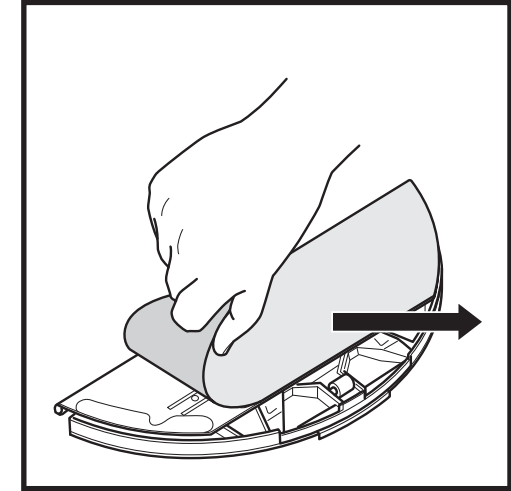

2. Slide the pad to one side, away from the pad plate.

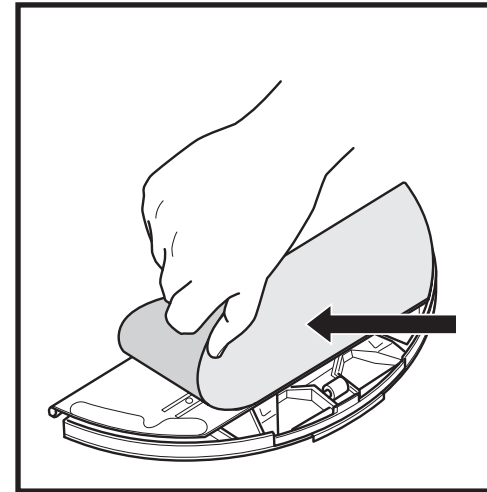

3. Slide a clean or new pad into the edge of the pad plate. Secure the pad to the plate with a light press to engage the Velcro.

**NOTE:** Mop pad colour may vary.

## MAINTENANCE

**CAUTION:** Turn off power and remove the robot's water tank before performing any maintenance. To turn the robot power off, press and hold the DOCK icon  on the robot for 5-7 seconds.

### CLEANING THE ROBOT FILTER

For optimal suction power, clean the filter inside the robot's dust bin.

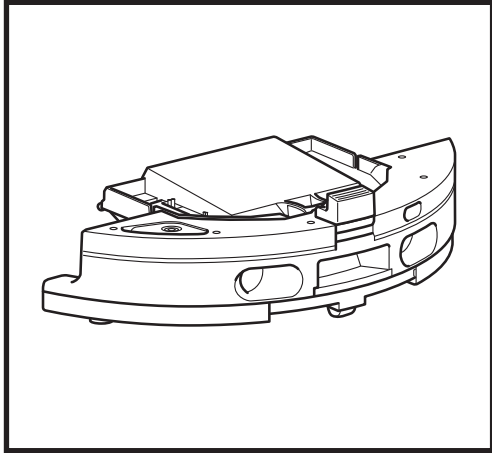

1. Remove and empty the dust bin. Clean any hair or debris off the back of the dust bin.

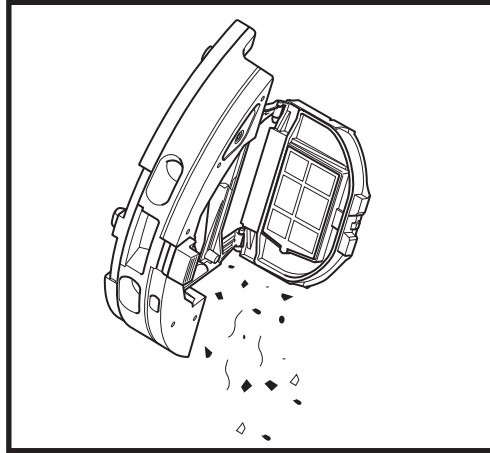

2. Every time you empty the dust bin, slide the filter out and lightly tap it over a trash can to remove any dust and dirt. Use a dry cloth or soft brush to remove any remaining debris.

**DO NOT** use water or soap to clean this filter as this will cause damage.

### CLEANING THE SIDE BRUSH

CLEAN SIDE BRUSH AS NEEDED.

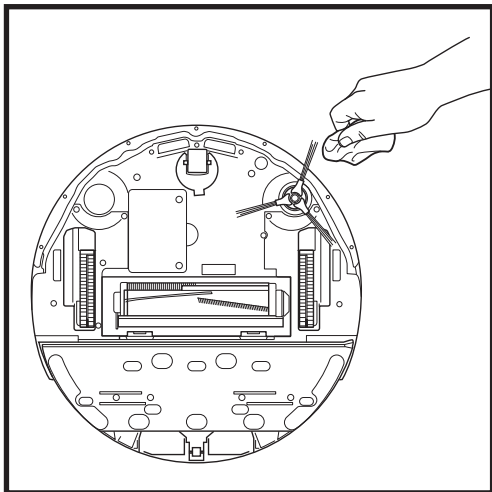

1. Remove the side brush from the robot.
2. Carefully unwind and remove any string or hair wrapped around the brush or gear.
3. Gently wipe brush with a dry cloth. To reinstall, snap the brush over the peg. Spin the brush manually to make sure it is installed correctly.

## MAINTENANCE

**CAUTION:** Turn off power and remove the robot's water tank before performing any maintenance. To turn the robot power off, press and hold the DOCK icon  on the robot for 5-7 seconds.

### CLEANING THE SENSORS

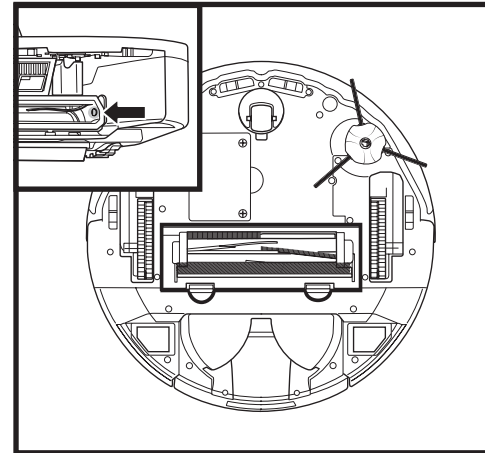

**CLEAN SENSORS AND CHARGING CONTACTS AS NEEDED.**

- The sensors on the robot require occasional maintenance.
- With a dry cloth or cotton swab, gently dust off the sensors located on the bottom and sides of the robot.

**IMPORTANT:** The robot uses cliff sensors to avoid stairs and other steep drops. Sensors may work less effectively when they are dirty. For best results, clean sensors once every 30 days or as needed.

**CAUTION:** Turn off power before performing any maintenance. To turn the base power off, simply unplug it from the electrical outlet.

### CLEANING THE BASE CHARGING CONTACTS

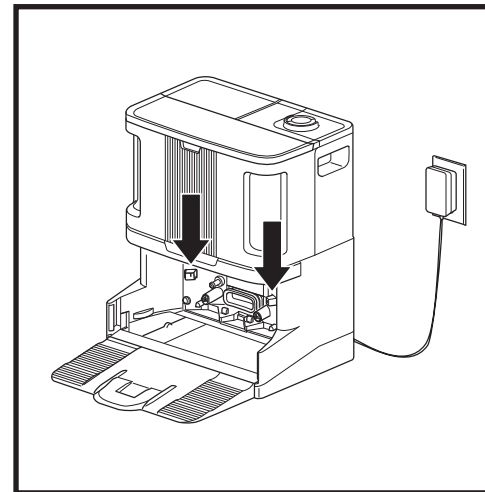

- Locate the charging contacts on either side of the base.
- These sensors require occasional maintenance.
- With a dry cloth, gently dust off both charging contacts on the base, removing any dust or debris that might impact robot docking performance.

## MAINTENANCE

**CAUTION:** Turn off power and remove the robot's water tank before performing any maintenance. To turn the robot power off, press and hold the DOCK icon  on the robot for 5-7 seconds.

### BRUSHROLL

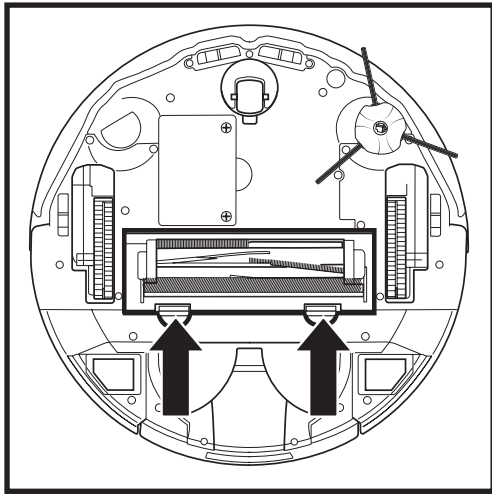

1. To access the brushroll, push up on the tabs on the brushroll door, then lift off the door.

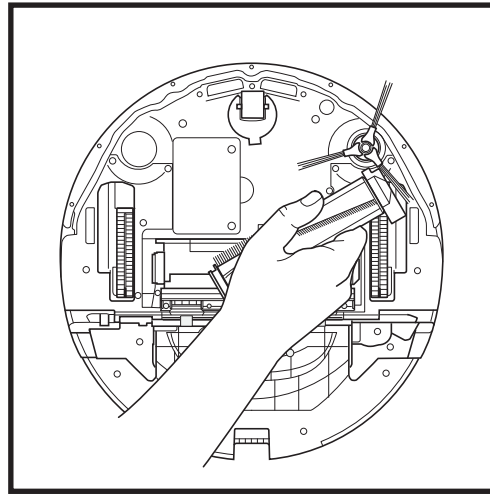

2. Take out the brushroll and remove the cap on the end. Clean off any hair or debris then replace the cap. Reinstall the brushroll, inserting the flat end first. Close the brushroll access door and press down until both sides click into place.

**NOTE:** Replace brushroll every 6 to 12 months, or when visibly worn.

### LIDAR MODULE

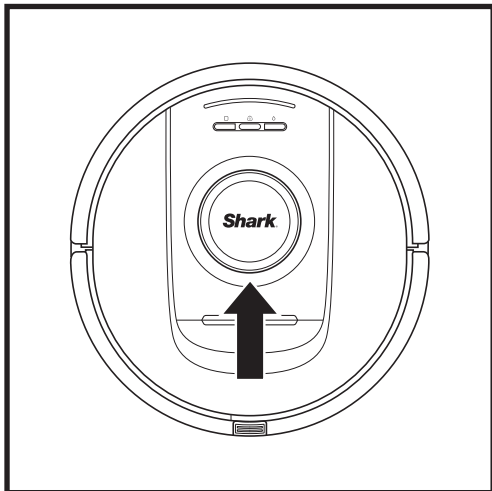

1. Check the navigation module on top of the robot and gently remove any hair or debris.
2. For a more complete clean, place the robot on a level surface and turn off the power.
3. Use compressed air to blow away any dirt or debris from the gap around the rotating LiDAR module.
4. It is also recommended to use a cotton bud to clean the lidar turret by spinning the lidar module manually 5 times in both directions.

## MAINTENANCE

**CAUTION:** Turn off power and remove the robot's water tank before performing any maintenance. To turn the robot power off, press and hold the DOCK icon  on the robot for 5-7 seconds.

### CLEANING THE WHEELS

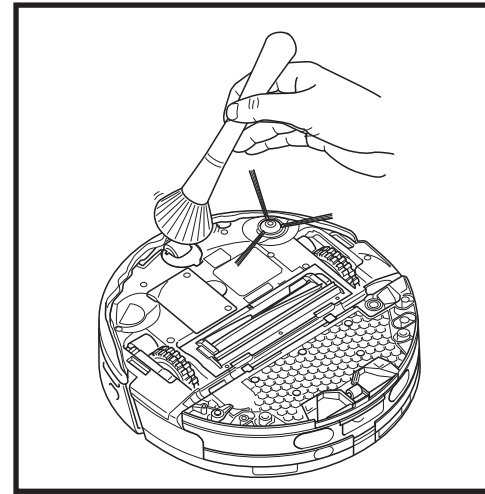

1. Rotate the front wheel while lightly brushing away dirt and debris. Clean the wheel and the housing around it.

**CLEAN FRONT WHEEL HOUSING PERIODICALLY.**

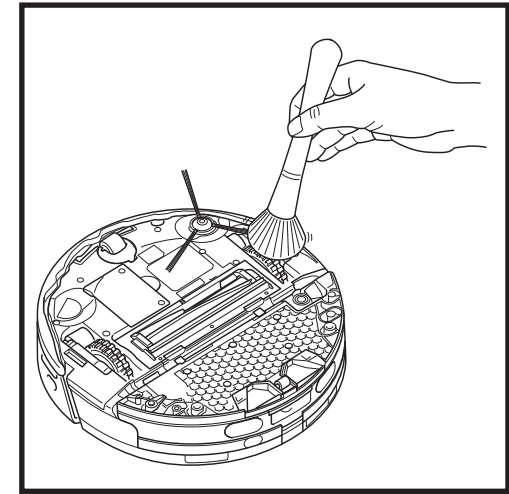

2. Periodically clean the drive wheels and the housing around them. To clean, rotate each drive wheel while dusting.

**NOTE:** Brush not included.

### CLEANING THE DIRTDETECT SENSORS

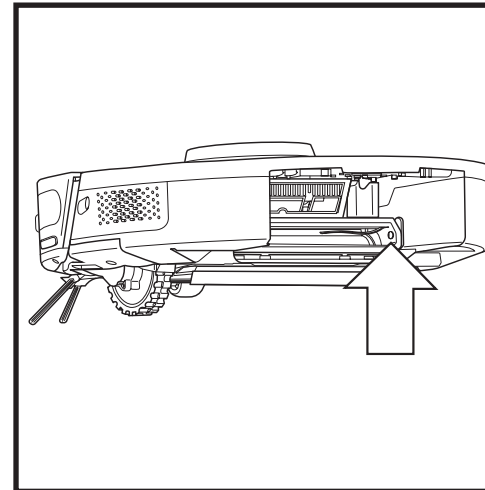

Remove the robot dust bin. Using a dry microfibre cloth, wipe off the area indicated to remove any dust or debris covering the sensor.

## UNDERSTANDING THE ROBOT USER INTERFACE

If any lights are illuminated or flashing on your robot, refer to the chart below to understand why:

LED COMBINATION	FUNCTIONALITY
<b>ALL LEDS (WHITE) - FLASHING</b>	Robot is booting up.
<b>ALL LEDS (WHITE) - SOLID</b>	Robot finishes booting up and enters standby mode. Robot is waiting for commands.
<b>ALL LEDS (GREEN) - SOLID</b>	Battery level 80%-100%.
<b>4 LEDS (GREEN) - SOLID RIGHT LED (OFF)</b>	Battery level 60%-79%.
<b>LEFT LED (YELLOW) + NOTIFICATION LED (YELLOW) + BATTERY LED (YELLOW)</b>	Battery level 40%-59%.
<b>LEFT LED (YELLOW) + NOTIFICATION LED (YELLOW)</b>	Battery level 20%-39%.
<b>LEFT LED (RED) - SOLID</b>	Battery level 0%-19%.
<b>ALL LEDS (GREEN) - BREATHE</b>	Robot is making its way back to the base.
<b>LEDS COMPLETE CELEBRATION SEQUENCE</b>	Robot returns to base successfully.
<b>WIFI LED (BLUE) - BREATHE</b>	Robot is connecting to WIFI.
<b>LEDS COMPLETE CELEBRATION SEQUENCE</b>	WIFI connection is successful.
<b>ALL LEDS (GREEN) - BREATHE</b>	Robot is evacuating dry debris into the base dust bin.
<b>BATTERY LED (RED) - SOLID</b>	Robot has low battery.
<b>ALL LEDS (WHITE) - FLASH x2</b>	Robot has been paused.
<b>ALL LEDS (PURPLE) - FLASH</b>	Robot has enabled DirtDetect mode.
<b>BATTERY LED: • GREEN BREATHE: 66-100% • YELLOW BREATHE: 33-65% • RED BREATHE: 5-32%</b>	Robot is on the base and charging.
<b>ALL LEDS (TURQUOISE) - FLASH</b>	Robot is activating pad shift during a wet cleaning mission along a wall.
<b>ALL LEDS (TURQUOISE) - BREATHE</b>	Robot is saturating the pad at the start of a wet cleaning mission.
<b>ALL LEDS (TURQUOISE) - FILL FROM ONE SIDE TO OTHER</b>	The base is refilling the robot's water tank before a wet cleaning mission.

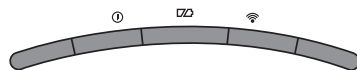

## COMMON ERROR CODES

If any error lights are illuminated or flashing on your robot, refer to the error code chart below:

ERROR CODE	ERROR NUMBER	SOLUTION
<b>BATTERY LED (RED) + WIFI LED (RED)</b>	<b>2</b>	Side brush is stuck. Remove any debris from around the side brush so it moves freely.
<b>NOTIFICATION LED (RED) + WIFI LED (RED) + RIGHT LED (YELLOW) - ALL FLASHING</b>	<b>3</b>	Suction motor failure. Remove and empty the dust bin, clean the filters, remove the brushroll and brushroll door, and remove blockages.
<b>NOTIFICATION LED (RED) + RIGHT LED (YELLOW)</b>	<b>4</b>	Blockage in brushroll. Remove any debris from around and inside the brushroll so that it can spin freely.
<b>BATTERY LED (RED) + WIFI LED (RED) + RIGHT LED (YELLOW)</b>	<b>5</b>	A drive wheel is stuck. Clean the wheels and remove any debris wrapped around the axles so they can move freely.
<b>WIFI LED (RED) + RIGHT LED (YELLOW)</b>	<b>6</b>	Front bumper may be jammed. Clean the bumper and make sure it moves in and out freely.
<b>NOTIFICATION LED (RED) + WIFI LED (RED)</b>	<b>7</b>	Cliff sensor error. Move your robot to a new location and clean its cliff sensors.
<b>BATTERY LED (RED) + RIGHT LED (YELLOW)</b>	<b>9</b>	Robot dust bin needs to be reinstalled. Insert the dust bin until it clicks in place.
<b>WIFI LED (RED)</b>	<b>10</b>	Robot may be stuck on an obstacle. Move robot to a new location on a level surface.
<b>NOTIFICATION LED (RED)</b>	<b>16</b>	Robot is stuck. Move your robot to a new location and make sure the front bumper moves in and out freely.
<b>NOTIFICATION LED (RED) + BATTERY LED (RED) + WIFI LED (RED)</b>	<b>23</b>	Robot cannot find the base. Please make sure the base is powered ON and is free of all obstacles.
<b>LEFT LED (RED) FLASHING</b>	<b>24</b>	Battery is critically low and needs recharging. Please pick up your robot and place it on the base. Make sure the base indicator light turns blue to confirm your robot is placed on the base and charging.
<b>NOTIFICATION LED (RED) + BATTERY LED (RED) + WIFI LED (RED) + RIGHT LED (YELLOW)</b>	<b>26</b>	Blockage in dust bin. Check the evacuation port on the base and robot dust bin for clogs. Clear any debris and reinstall the base dust bin, ensuring that it clicks into place.
<b>RIGHT LED (RED) FLASHING</b>	<b>33</b>	There may be a blockage with Active Lift. Turn off the robot and ensure that there is nothing blocking the wheel suspension from moving up and down.
<b>LEFT LED (PINK) + RIGHT LED (PINK) - ALL FLASHING</b>	<b>36</b>	There may be a blockage in the base. Unplug the base and ensure that there is nothing blocking the space where the robot sits in the base.

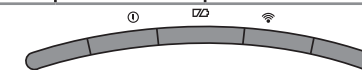

**NOTE:** To order replacement visit [sharkclean.co.uk](http://sharkclean.co.uk)

## REPLACEMENT PARTS: ROBOT

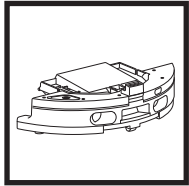

Robot Dust Bin

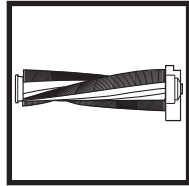

Brushroll

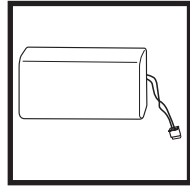

Battery

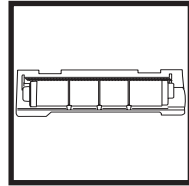

Brushroll Door

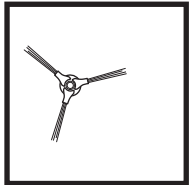

Side Brush

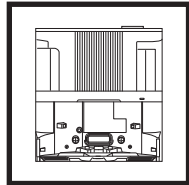

NeverTouch Base

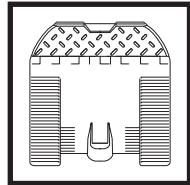

NeverTouch Base Ramp

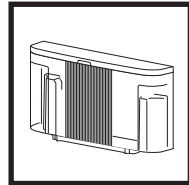

NeverTouch Clean Water Tank

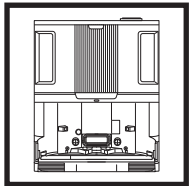

NeverTouch Pro Base

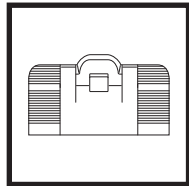

NeverTouch Pro Base Ramp

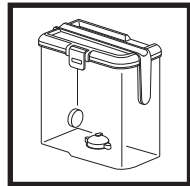

NeverTouch Pro Clean Water Tank

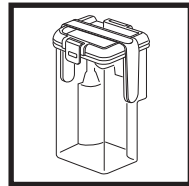

NeverTouch Pro Grey Water Tank

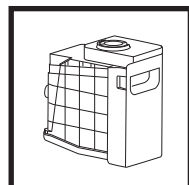

Base Dust Bin

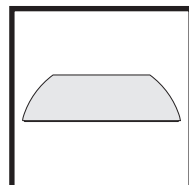

Mop Pad

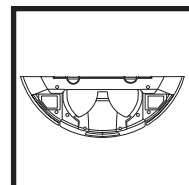

Pad Plate

**IMPORTANT: PLEASE READ THE TERMS AND CONDITIONS OF THIS LICENCE AGREEMENT CAREFULLY BEFORE COMMENCING USE OF THIS PRODUCT**

This End-User License Agreement ("EULA") is a legal agreement between you and SharkNinja Operating LLC's ("SharkNinja", "us" or "we") for [the]/[SharkNinja's] computer software which is preinstalled on your SharkNinja device, which you download in order to control the SharkNinja device from your phone or computer, or, in either case, is made available by way of updates (the "Software"), as well as any printed, online or electronic documents related to the Software (the "Documentation").

We grant you the right to use of the Software and Documentation on the terms of this License. We do not sell the Software or Documentation to you. We remain the owners of the Software and Documentation at all times. If you do not agree to the terms of this EULA, do not install or use the Software, the Documentation or the SharkNinja device. In that case, you may return the unused SharkNinja device to us for a full refund. This does not affect your legal rights to return goods to your retailer if you change your mind or if they are faulty, or the terms of our separate manufacturer's guarantee, if any.

**1. GRANT OF LICENSE.**

Installation and Use. In return for you agreeing to comply with the terms of this EULA, SharkNinja grants you the right to use the Software and Documentation, and to receive and use any free supplementary software code or update of the Software incorporating "patches" and corrections of errors as may be provided by the Licensor from time to time, solely for the purpose of domestic operation and use of the SharkNinja device in relation to which the Software was supplied.

**2. DESCRIPTION OF OTHER RIGHTS AND LIMITATIONS.**

- 2.1. Maintenance of Copyright Notices. You must not remove or alter any copyright notices on any and all copies of the Software and Documentation.
- 2.2. Copying and Distribution. You must not make or distribute to third parties copies of the Software or the Documentation.
- 2.3. Prohibition on Reverse Engineering, Decompilation, and Disassembly. You must not reverse engineer, decompile, or disassemble the Software, except and only to the extent that such activity is expressly permitted by applicable law notwithstanding this limitation.
- 2.4. Rental. You must not rent, lease, or lend the Software or the Documentation without written permission from SharkNinja.
- 2.5. "Not for resale" software. Software identified as "Not for Resale" or "NFR", must not be resold, transferred, or used for any purpose other than demonstration, test, or evaluation.
- 2.6. Support Services. SharkNinja may provide you with support services related to the Software or your SharkNinja device (the "Support Services"). Any supplemental software code provided to you as part of the Support Services shall be considered part of the Software and be subject to the terms and conditions of this EULA.
- 2.7. Ownership of Software. SharkNinja retains ownership of all intellectual property rights in the Software and the Documentation.
- 2.8. Compliance with Applicable Laws. You must comply with all applicable laws regarding use of the Software and Documentation.

**3. UPDATES.**

SharkNinja may upgrade or update, or require you to upgrade or update, the Software, provided that the Software shall always match the description of it that we provided to you before you bought your SharkNinja device. This EULA will govern any upgrades or updates provided by SharkNinja that replace and/or supplement the Software supplied pre-loaded to your SharkNinja device, unless such upgrade is accompanied by a separate End User Licence Agreement, in which case the terms of that End User Licence Agreement will govern.

**4. DATA AND PRIVACY.**

SharkNinja is committed to ensuring your privacy by adhering to high standards of fairness and integrity, and complying with applicable data protection laws. We are committed to keeping our customers informed about how we use the information we gather from you through the use of the Software. Our privacy practices are described in SharkNinja's Privacy Policy, as well as in separate notices given when an app, product, or service is purchased or downloaded. At all times your information will be treated in accordance with the SharkNinja Privacy Policy, which is incorporated by reference into this EULA and can be viewed at the following URL: <https://ninjakitchen.co.uk/systempage.privacypolicy.pagelet2-page-cms-systempage.privacypolicy.pagelet2-Page>. Please read and review our Privacy Policy and any other relevant privacy notices carefully to understand how your personal data is collected, processed and shared by SharkNinja, and your data subject rights in relation to such data.

## 5. THIRD-PARTY APPLICATION LIBRARIES AND EMBEDDED SOFTWARE

- 5.1 You acknowledge that Amazon Web Services, Inc. (“AWS”) has provided certain application libraries that have been embedded into the Software (“AWS Application Libraries”) and enables SharkNinja devices to connect to the AWS Cloud Service (“AWS Embedded Software”).
- 5.2 You must not use the AWS Application Libraries except as an incorporated portion of the Software, unmodified from the form provided to you.
- 5.3 You must not use the AWS Embedded Software except as an incorporated portion of your SharkNinja device, unmodified from the form provided to you.
- 5.4 You must not reverse engineer, decompile, or disassemble the AWS Application Libraries or the AWS Embedded Software, except and only to the extent that such activity is expressly permitted by applicable law notwithstanding this limitation.
- 5.5 SharkNinja retains ownership of all intellectual property rights in the AWS Application Libraries and the AWS Embedded Software incorporated into the Software.
- 5.6 You must not use the AWS Application Libraries or AWS Embedded Software to attempt to gain unauthorised access to or use of the systems/services of SharkNinja’s other licensors; nor will you transmit viruses, worms, Trojan horses, time bombs, spyware, malware, cancelbots, passive collection mechanisms, robots, data mining software, or any other malicious or invasive code or program into the systems/services of SharkNinja’s other licensors.
- 5.7 You will not use the AWS Application Libraries or AWS Embedded Software to interfere with, breach, or circumvent any security feature, authentication feature, or any other feature that restricts or enforces limitations on the use of, or access to, the systems/services of SharkNinja’s other licensors.
- 5.8 You will not probe, attack, scan, or test the vulnerability of the systems/services of SharkNinja’s other licensors.
- 5.9 SharkNinja’s other licensors of the Software, AWS Application Libraries, and the AWS Embedded Software, are the express third-party beneficiaries of this EULA, and the provisions of this Section of this EULA are made expressly for the benefit of such licensors, and are enforceable by such licensors.

**6. TERMINATION.** Without prejudice to any other rights, SharkNinja may terminate this EULA if you commit a material or persistent breach of this EULA which you fail to remedy (if remediable) within 14 days after the service of written notice requiring you to do so. Upon termination for any reason, all rights granted to you under this EULA shall cease, you must cease all activities authorised by this EULA, and you must immediately delete or remove the Software from all computer equipment in your possession and immediately destroy or return to us (at our option) all copies of the Software then in your possession, custody or control.

## 7. OUR RESPONSIBILITY FOR LOSS AND DAMAGE CONSUMERS SUFFER.

- 7.1.** The Software is for domestic and private use. If you use the Software for any commercial, business or resale purpose we will have no liability to you for any loss of profit, loss of business, business interruption, or loss of business opportunity.
- 7.2 You acknowledge that the Software has not been developed to meet Your individual requirements, and that it is therefore Your responsibility to ensure that the Software as described in the Documents meets your requirements.
- 7.3 We are responsible for loss or damage you suffer that is a foreseeable result of our breaking this EULA or our failing to use reasonable care and skill, but we are not responsible for any loss or damage that is not foreseeable, except as set out at 7.3 to 7.4 below. Loss or damage is foreseeable if either it is obvious that it will happen or if, at the time this EULA came into force, both we and you knew it might happen.
- 7.4 If defective digital content that we have supplied damages a device or digital content belonging to you, then, in accordance with section 46 of the Consumer Rights Act 2015, we will either repair the damage or pay you compensation. However, we will not be liable for damage that you could have avoided by following our advice to apply an update or upgrade offered to you free of charge or for damage that was caused by you failing to correctly follow installation instructions or to have in place the minimum system requirements advised by us.
- 7.5 If you bought the SharkNinja device directly from SharkNinja or one of its group companies, we or our group company, as the seller, may be responsible to you under the contract of sale for loss or damage caused by your use of the Software. You can find our terms and conditions of sale here: <https://ninjakitchen.co.uk/terms-and-conditions>. If you bought the SharkNinja device from another company, they may have a similar responsibility to you.
- 7.6 Many SharkNinja products come with a free manufacturer’s guarantee. If you suffer loss or damage as a result of using the Software, you may be able to claim under the guarantee. You can find the terms of our guarantee here: <https://support.ninjakitchen.co.uk/hc/en-gb/articles/360013838359-Ninja-Guarantee-Terms-Conditions>.
- 7.7 We do not exclude or limit in any way our liability to you where it would be unlawful to do so. This includes liability for death or personal injury caused by our negligence or the negligence of our employees, agents or subcontractors or for fraud or fraudulent misrepresentation.

**8. APPLICABLE LAW AND JURISDICTION.** This EULA is governed by English law and you can bring legal proceedings in respect of the products in the English courts. If you live in Scotland you can bring legal proceedings in respect of the products in either the Scottish or the English courts. If you live in Northern Ireland you can bring legal proceedings in respect of the products in either the Northern Irish or the English courts.

**9. ASSIGNMENT.** We may transfer our rights and obligations under this EULA to another organisation. We will always tell you in writing if this happens and we will ensure that the transfer will not affect your rights under the EULA.

## MANUFACTURER’S GUARANTEE

### The Shark Guarantee

When a consumer buys a product in the UK, they get the benefit of legal rights relating to the quality of the product (your “legal rights”). You can enforce your legal rights against your retailer, including Shark if you bought your appliance from [sharkclean.co.uk](http://sharkclean.co.uk). However, at Shark we are so confident about the quality of our products that we give the owner an additional, free parts and labour manufacturer’s guarantee of up to 2 years.

The guarantee it comes with is an important consideration - and reflects how much confidence the manufacturer has in its product and manufacturing quality.

The manufacturer’s guarantee does not affect your legal rights.

### How long are new Shark machines guaranteed for?

Our manufacturer’s guarantee lasts for one year from the date of purchase as standard, or for two years if you register your purchase with us within 28 days.

### How do I register my Shark guarantee?

If you have purchased your Shark appliance directly from [sharkclean.co.uk](http://sharkclean.co.uk) your guarantee is registered automatically. If you bought it from anywhere else in the UK, you can register your guarantee online within 28 days of purchase.

- To register online, please visit [sharkclean.co.uk/register-guarantee](http://sharkclean.co.uk/register-guarantee) or scan the QR code in your instruction booklet.
- Keep a note of the date you purchased the machine.

### IMPORTANT:

- Keep your receipt if you bought your Shark appliance from anywhere except [sharkclean.co.uk](http://sharkclean.co.uk). You will need it to claim under your guarantee.
- The free Shark guarantee only applies in the UK.

### What are the benefits of registering my free Shark guarantee?

When you register your guarantee, you will get an extra one year of cover. We’ll also have your details to hand if we ever need to get in touch. If you further agree to receive communications from us, you can also receive tips and advice on how to get the best out of your Shark appliance and hear the latest news about new Shark technology and launches.

### What is covered by the free Shark guarantee?

Repair or replacement (at Shark’s discretion) of your Shark machine, including all parts and labour.

### What is not covered by the free Shark guarantee?

- Normal wear and tear.
- Accidental damage or faults caused by negligent use or care, misuse, neglect, careless operation or handling of the Shark appliance which is not in accordance with the Shark Operating Manual supplied with your machine.
- Damage caused by use of the Shark appliance for anything other than normal domestic household purposes.
- Damage caused by use of parts not assembled or installed in accordance with the operating instructions.
- Damage caused by use of parts and accessories which are not Shark Genuine Components
- Faulty installation (except where installed by Shark).
- Repairs or alterations carried out by parties other than Shark or its agents.

## MANUFACTURER'S GUARANTEE

### How can I claim under the free Shark guarantee?

Contact our customer service helpline on 0800 862 0453. For service hours please visit our website under 'Contact Us'. It's free to call, and you'll be put straight through to a Shark representative. You'll also find online support at [support.sharkclean.co.uk](http://support.sharkclean.co.uk). The Shark representative will go through some troubleshooting with you, and if we conclude that the item has failed, we will send you a replacement part or a returns label to send the defective item back to us free of charge. When you have delivered the defective product to us, we will send you a replacement.

Please remember that the item will need to be boxed when you return it to us. It can be any suitable box, it does not have to be the original packaging.

### Where can I buy genuine Shark spares and accessories?

Shark spares and accessories are developed by the same engineers who developed your Shark appliance. You'll find a full range of Shark spares, replacement parts and accessories for all Shark machines at [sharkclean.co.uk](http://sharkclean.co.uk). Please remember that damage caused by the use of non-Shark spares may not be covered under your guarantee.

These instructions are designed to help you keep your Shark Robot running at peak performance.

#### SharkNinja Europe Ltd,

1st/2nd Floor Building 3150,  
Thorpe Park,  
Century Way,  
Leeds, England,  
LS15 8ZB

#### SharkNinja Germany GmbH,

Rotfeder-Ring 9,  
60327 Frankfurt am Main, Germany  
[sharkclean.co.uk](http://sharkclean.co.uk)

Illustrations may differ from actual product. We are constantly striving to improve our products; therefore the specifications contained herein are subject to change without notice.

## ROBOT VACUUM WARRANTY COVERAGE & PARTS GUIDE

**NOTE:** Warranty covers manufacturing defects, internal hardware or software malfunctions, and structural failures caused by manufacturing defects. It does not cover damage from misuse, accidents, or unauthorized repairs, normal wear and tear, or consumable parts (unless defective upon first use). Please refer to the table below to understand what parts are covered by warranty.

Robot Component	Maintenance Frequency	Replacement Frequency	Category	Warranty Coverage
Robot Pod	Clean sensors and charging contacts monthly, or as needed.	N/A	Non-Wearable	Yes
Brushroll	Clean monthly, or as needed.	Every 6-12 months, or as needed.	Wearable	No (unless defective)
Filter	Clean monthly, or as needed.	Every 6-12 months, or as needed.	Wearable	No
Dust Cup	Clean monthly, or as needed.	As needed.	Wearable	No (unless defective)
Mop Pad	After every wet cleaning mission, the base will automatically wash and dry the mop pad. Additional cleaning in a washing machine may be needed occasionally.	Every 2 years, or as needed.	Wearable	No
Side Brush	Clean monthly, or as needed.	Every 3-6 months, or as needed.	Wearable	No (unless defective)
Battery	N/A	Every 12-24 months, or as needed.	Wearable	Yes (within warranty)

Base Component	Maintenance Frequency	Replacement Frequency	Category	Warranty Coverage
Multi-functional Base	Clean monthly, or as needed.	N/A	Non-Wearable	Yes
Dust Bin	Empty every 60 days, or as needed.	As needed.	Wearable	No (unless defective)
Pre-Motor Filters	Clean monthly, or as needed.	Every 6-12 months, or as needed.	Wearable	No
Post-Motor Filter (HEPA)	Clean every 6 months, or as needed.	Once a year, or as needed.	Wearable	No
Ramp	Clean monthly, or as needed.	As needed.	Wearable	No (unless defective)
Greywater Grate	Clean every 30 days, or as needed.	As needed.	Wearable	No (unless defective)

Illustrations may differ from actual product  
We are constantly striving to improve our products; therefore  
the specifications contained here in are subject to change  
without notice.

© 2025 SharkNinja Operating LLC. SHARK is a registered  
trademark in the European Union of SharkNinja Operating LLC.  
Apple App Store is a trademark of Apple Inc.  
Google, Android and Google Play are trademarks of Google LLC.



[sharkclean.co.uk](https://sharkclean.co.uk)

© 2025 SharkNinja Operating LLC.  
RV2800ZEUK\_RV2800YEUK\_IB\_MP\_Mv4\_251113