

Shark[®] **ROTATOR**[™]

SLIM-LIGHT
Lift-Away[™]

OWNER'S GUIDE

NV340UK



Thank you for purchasing the Shark® Rotator™ Slim Lift-Away™ Vac.

For a list of what is included with this model, refer to inside flap of box.

This Owner's Guide is designed to help you get a complete understanding of your new vacuum cleaner. Please read it carefully and keep it for future reference.

THANK YOU!

RECORD THIS INFORMATION:

Model Number: _____

Date of Purchase (Keep receipt):

TECHNICAL SPECIFICATIONS:

Voltage: 220-240V~, 50/60Hz

Watts: 750W

Power Nozzle: 80W

RECOMMENDED FILTER CLEANING SCHEDULE:

See the MAINTENANCE section for filter cleaning instructions

| | | |
|--------------|------------------|-----------------|
| Foam filter: | 1229FC340 | Every 3 months |
| Felt Filter: | 1229FC340 | Every 3 months |
| HEPA Filter: | XHF340 | Every 12 months |

This appliance complies with the WEEE-Directive 2012/19/EU on the disposal of electrical and electronic equipment (WEEE).



This marking indicates that this product should not be disposed with other household wastes throughout the EU. To prevent possible harm to the environment or human health from uncontrolled waste disposal, recycle it responsibly to promote the sustainable reuse of material sources. To return your used device, please use the return and collection systems or contact the retailer where this product was purchased. They can take this product for environmental safe recycling.

This appliance complies with the European directives for electromagnetic compatibility (EMC) 2014/30/EU and its revisions, as well as Low Voltage Directive (LVD) 2014/35/EU and its revisions.



IMPORTANT SAFEGUARDS

When using an electrical appliance, basic safety precautions should always be observed, including the following:

WARNING

This appliance is not intended for use by persons with reduced physical, sensory or mental capabilities, or lack of experience and knowledge, unless they have been given supervision or instruction concerning use of the appliance by a person responsible for their safety. Children shall not use or play with this appliance. Close supervision is necessary to keep appliance out of reach of children during use.

CAUTION

THE POWER NOZZLE, WAND, HOSE, AND HANDLE CONTAIN ELECTRICAL CONNECTIONS:

- These are not serviceable parts.
- Do not use to vacuum any liquids.
- Do not immerse in water when cleaning.
- Prior to use, inspect hose, handle/wand for damage. Discontinue using if damaged.

WARNING

TO REDUCE THE RISK OF FIRE, ELECTRIC SHOCK OR INJURY:

- 1 DO NOT use outdoors or on wet surfaces.
- 2 Unplug from electrical outlet when not in use and before cleaning or servicing.
- 3 Inspect power cord or plug for any damage before use. DO NOT use vacuum cleaner with a damaged cord or plug. Contact Customer Service or Service Center or similarly qualified person to replacement the line cord in order to avoid a hazard.
- 4 DO NOT use if the appliance is not working, has been dropped, dropped into water, damaged or left outdoors.
- 5 NO SERVICEABLE PARTS. Incorrect re-assembly or repair can cause a risk of electrical shock or injury to persons when the appliance is used. Contact Customer Service or a Service Center for the repair or replacement under the warranty agreement.
- 6 DO NOT pull or carry vacuum cleaner by the cord or use the cord as a handle.
- 7 DO NOT unplug by pulling on cord; to unplug, grasp the plug, not the cord.
- 8 DO NOT handle plug or vacuum cleaner with wet hands.
- 9 DO NOT run the vacuum cleaner over the power cord, close a door on the cord or pull cord around sharp corners.
- 10 The use of an extension cord is not recommended.
- 11 DO NOT leave vacuum cleaner when plugged in.
- 12 Keep cord away from heated surfaces.
- 13 Turn off all controls before plugging or unplugging the vacuum cleaner.
- 14 Always turn off the vacuum cleaner before connecting or disconnecting Power nozzle.
- 15 Store your vacuum cleaner with the power cord secured around the two cord holders.
- 16 This vacuum cleaner is equipped with a motor protective thermostat. If for some reason your vacuum overheats, the thermostat will automatically turn the unit off. Should this occur, refer to the troubleshooting guide.

GENERAL USE

- 17 Use only as described in this manual.
- 18 DO NOT put any objects into openings. DO NOT use with any opening blocked; keep free of dust, lint, hair, and anything that may reduce air flow.
- 19 Keep your work area well lit.
- 20 Keep the vacuum cleaner moving over the carpet surface at all times to avoid damaging the carpet fibers.
- 21 DO NOT place vacuum cleaner on unstable surfaces such as chairs or tables.
- 22 DO NOT use without dust cup and/or filters in place.
- 23 DO NOT step on, run over, or bend hose. The hose is powered by electrical wires that may be damaged as a result.

HOSE ATTACHMENTS

- 24 DO NOT use if air flow is restricted; if the air paths, the hose, or the accessories become blocked, turn the vacuum cleaner off. Remove all obstructions before you turn on the unit again.
- 25 Keep the end of the hose and accessory openings away from face and body.
- 26 Keep cleaning tools and hose suction openings away from hair, face, fingers, uncovered feet, or loose clothing.
- 27 Only use manufacturer's recommended attachments.

DUST CUP/FILTERS/ACCESSORIES

Before turning on the vacuum:

- 28 Make sure that all filters are thoroughly dry after routine cleaning.
- 29 Make sure that dust cup and all filters are in place after routine maintenance.
- 30 Make sure accessories are free of blockages.
- 31 Use only manufacturer's recommended accessories and replacement parts.

GENERAL CLEANING

- 32 DO NOT pick up large-sized objects.
- 33 DO NOT pick up hard or sharp objects such as glass, nails, screws or coins that could damage the vacuum cleaner.
- 34 DO NOT use to pick up drywall dust.
- 35 DO NOT pick up smoking or burning objects such as hot coals, cigarette butts, fireplace ash or matches.
- 36 DO NOT pick up flammable or combustible materials such as lighter fluid, gasoline, or kerosene or use vacuum in areas where they may be present.
- 37 DO NOT pick up toxic solutions such as chlorine bleach, ammonia, or drain cleaner.
- 38 DO NOT use in an enclosed space where vapors are present from paint, paint thinner, moth-proofing substances, flammable dust or other explosive or toxic materials.
- 39 DO NOT vacuum up any liquids.
- 40 DO NOT immerse vacuum cleaner in water or other liquids.
- 41 DO NOT use outdoors or on wet surfaces; use only on dry surfaces.
- 42 Use extra care when cleaning on stairs.

SAVE THESE INSTRUCTIONS

ASSEMBLY

- 1 Place the vacuum body onto floor nozzle
- 2 Insert the wand into top of the vacuum.
- 3 Insert the handle into the top of the wand.
- 4 Insert the hose into the hose connector.
- 5 Insert the crevice tool and dusting brush into the accessory holder as shown.

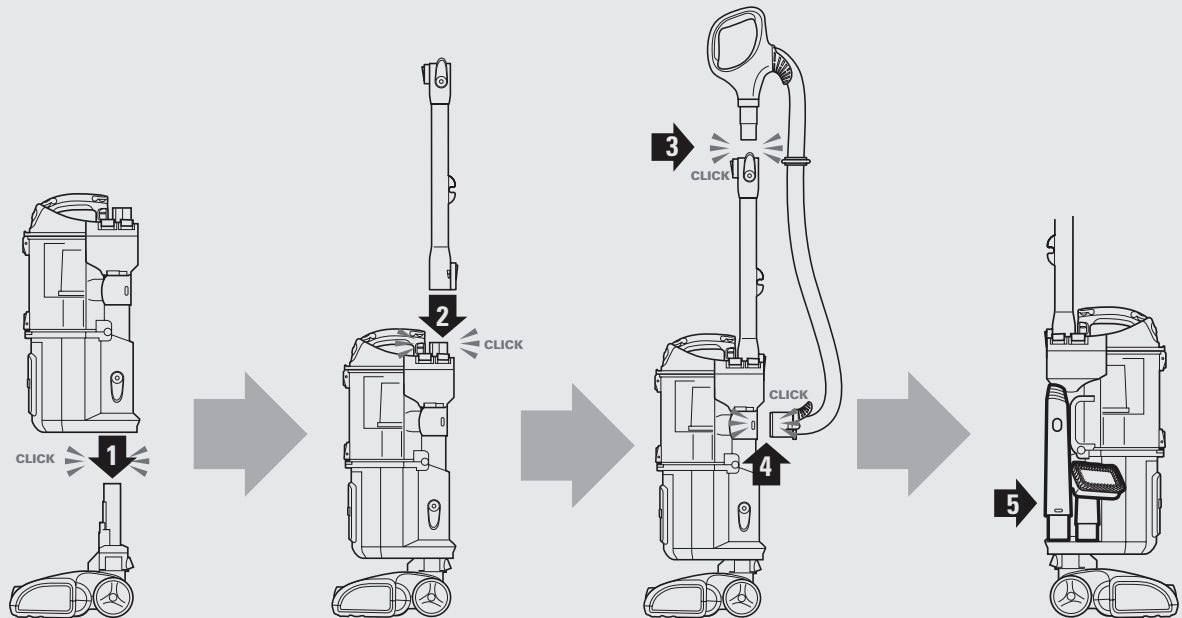

UPRIGHT CLEANING

- 1 Press POWER to clean bare floor surfaces, area rugs or areas above-floor. The brushroll will not spin in this mode.
- 2 Press POWER and BRUSHROLL to clean carpets. The brushroll indicator lights will illuminate GREEN. If there is a jam, the indicator light on floor nozzle will illuminate RED. Refer to MAINTENANCE (P12) for instructions on removing blockages.
- 3 Place your left foot gently on the floor nozzle and tilt the handle back to start cleaning. Note: The brushroll will only spin once the vacuum is reclined back.

ABOVE FLOOR CLEANING

- 4 To clean with the hose, press the WAND or HANDLE release button (depending on the amount of reach required) then lift the handle up.
- 5 Attach desired cleaning accessory. Note, the handle will slide into the accessory and the wand will slide over the accessory.

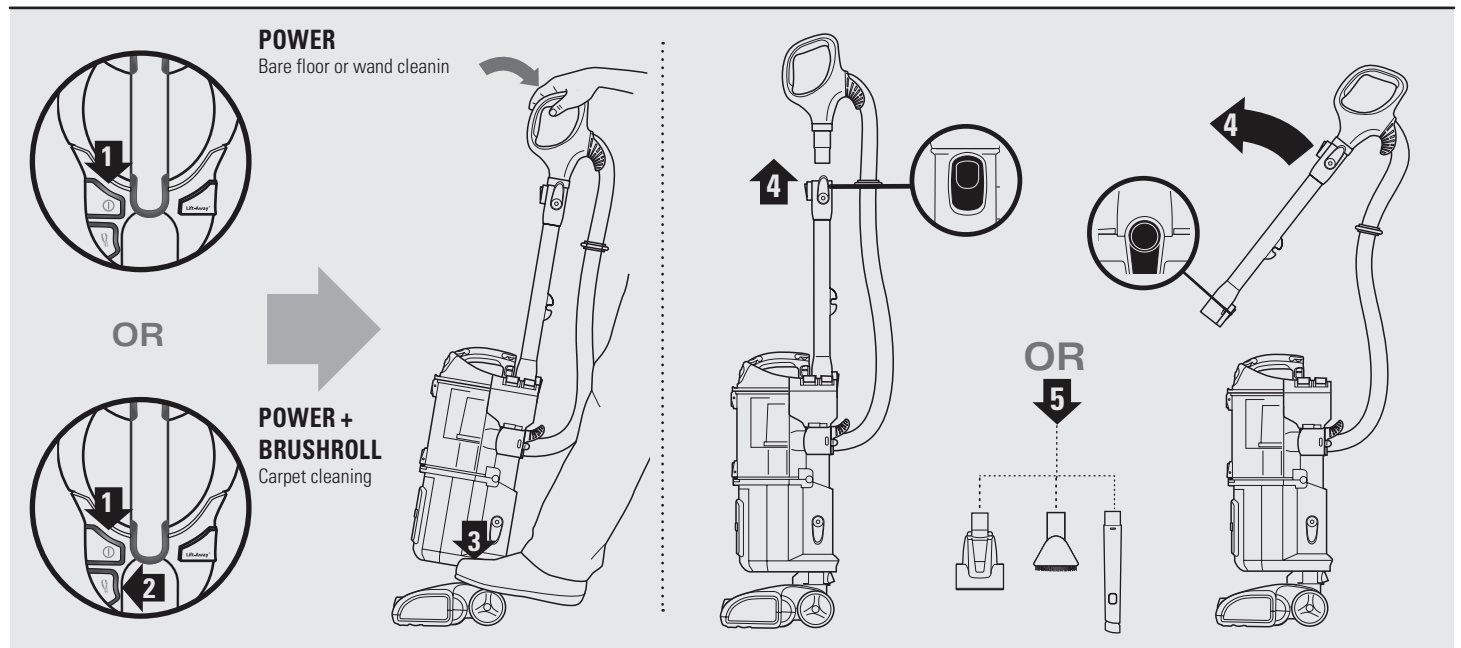

LIFT-AWAY™ CLEANING

Use for portable
cleaning on stairs
or anywhere

- 1 Press LIFT-AWAY to lift the pod off the floor nozzle.
- 2 To clean with the hose, press the WAND or HANDLE release button, then lift the handle up.

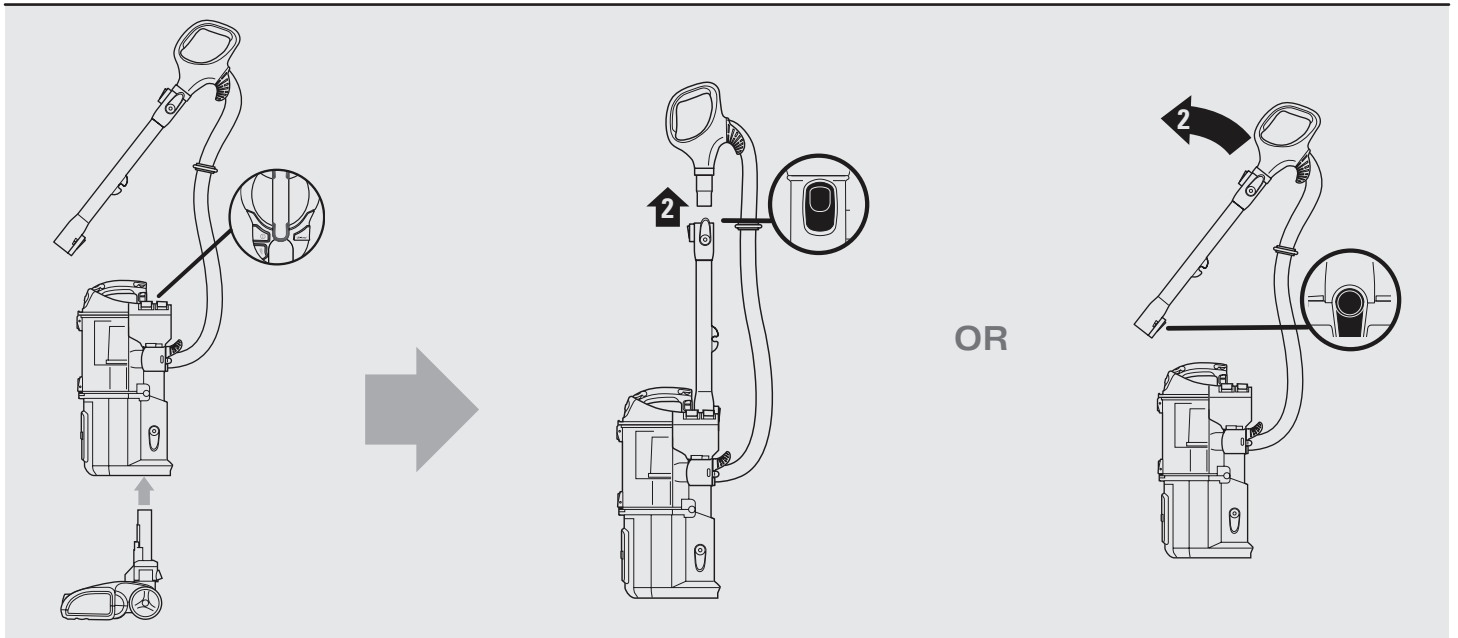

LIFT-AWAY™ CLEANING

Use for portable
cleaning on stairs
or anywhere

- 3 Attach the desired cleaning tool. Should you need to increase or decrease the amount of suction, refer to Helpful Tips (P10), SUCTION RELEASE.
- 4 Use the shoulder strap to facilitate cleaning while moving around.

NOTE: Select cleaning accessories are included with this model. Additional accessories are available for purchase.

SHOULDER STRAP - XTRP340

For a list of what is included with this model, refer to inside flap of box.

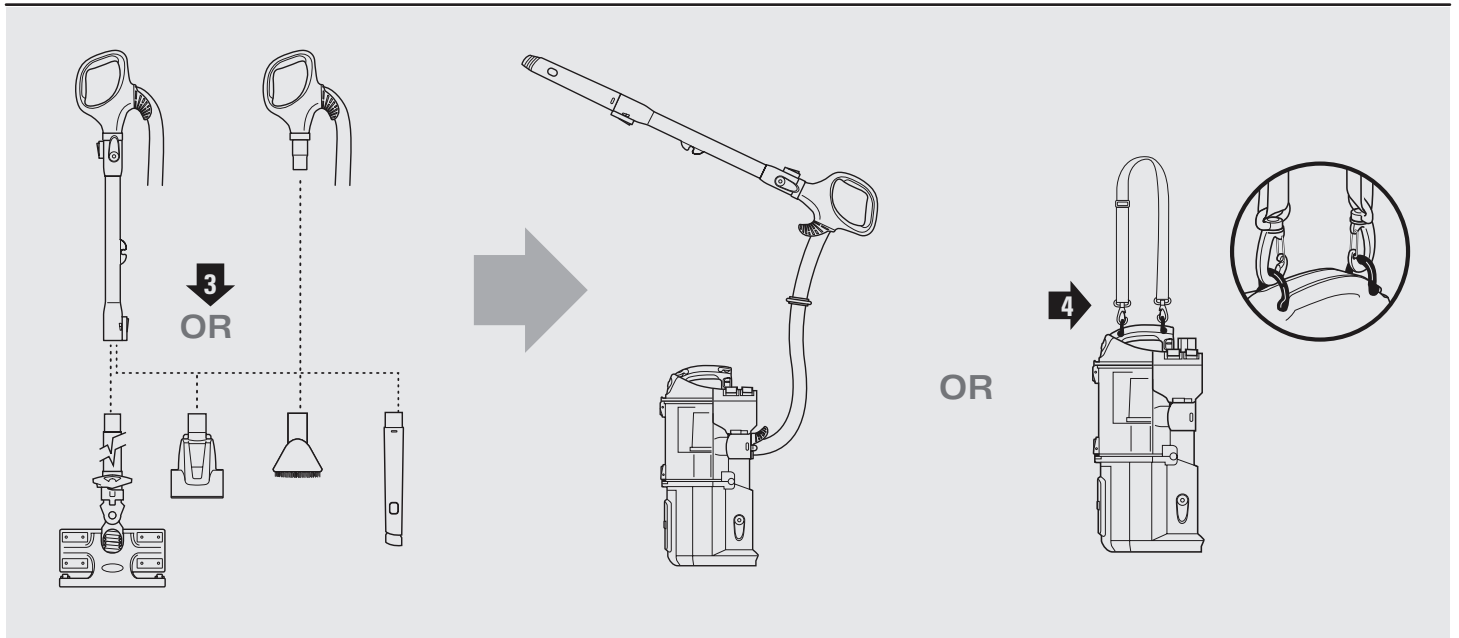

CANISTER CLEANING

Convert your upright to a convenient canister

- 1 From the Lift-Away™ mode, place the pod onto the canister caddy.
- 2 Press WAND release button then lift handle up.
- 3 Attach the desired cleaning tool. Should you need to increase or decrease the amount of suction, refer to Helpful Tips (P11), SUCTION CONTROL.
- 4 Use the posts on the caddy to store additional cleaning accessories while you clean.
- 5 To release pod from caddy, press LIFT-AWAY and continue to use with cleaning wand or replace wand and pod on Power nozzle per assembly instructions.

NOTE: Select cleaning accessories are included with this model. Additional accessories are available for purchase.

CANISTER CADDY - 3057FHW340

For a list of what is included with this model, refer to inside flap of box.

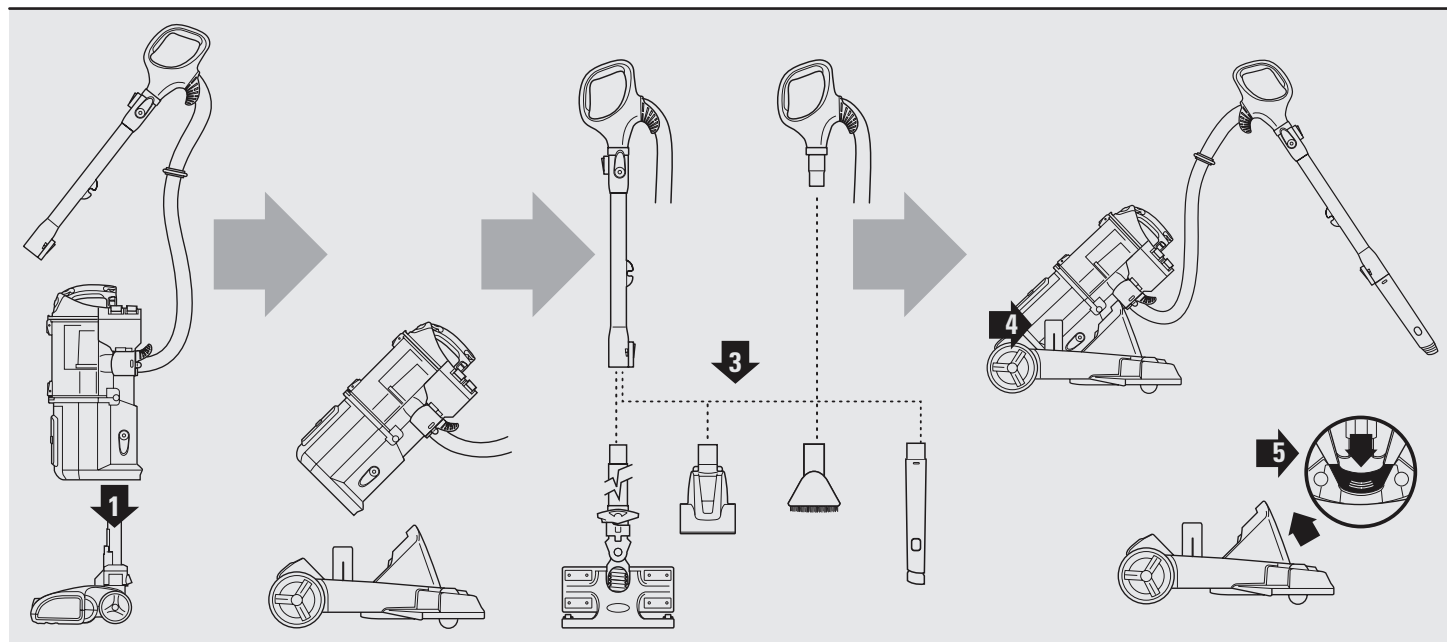

ACCESSORIES

Accessory Bag (not shown)

3053FLI340

NOTE: Select cleaning accessories are included. Others are available for purchase.

For a list of what is included with this model, refer to inside flap of box.

Crevice Tool

33 cm flexi — 3054FLI340

crevice tool for reaching hard to reach places.

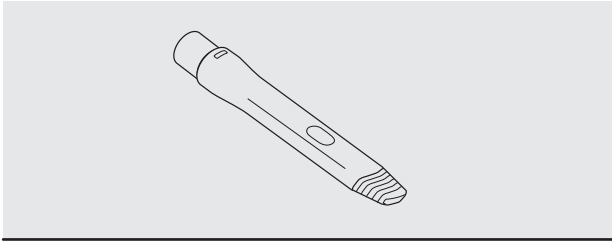

Power Brush

3056FLI340

Designed for removal of pet hair and ground in dirt from carpeted stairs and upholstery.

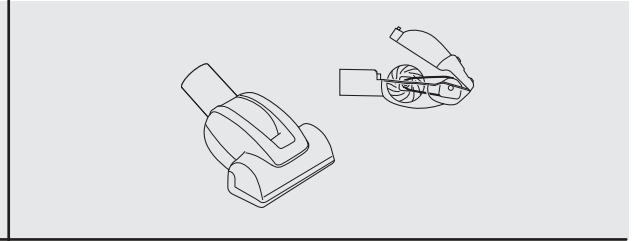

Dust-Away™ Hard Floor Attachment / 1 Dust-Away™ Pad

XDSTY340

Hard floor attachment vacuums up large particles, then re-usable microfiber pads trap extra fine dirt and dust for superior bare floor clean.

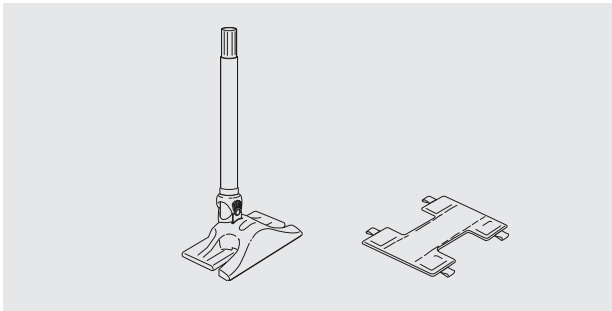

Dusting Brush

3050FC340

Cleans hard surfaces and upholstery.

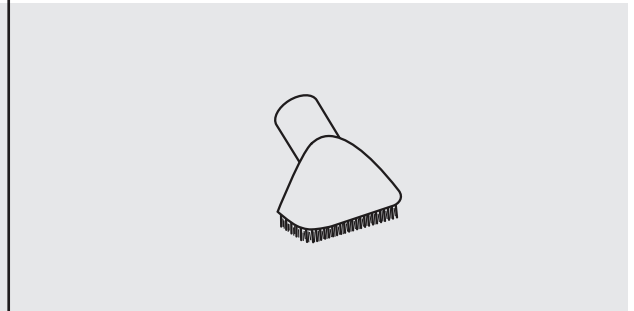

Cylinder Caddy

3057FHW340

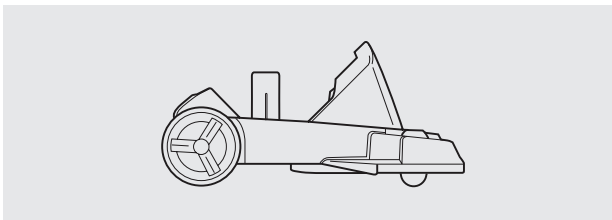

Shoulder Strap

XTRP340

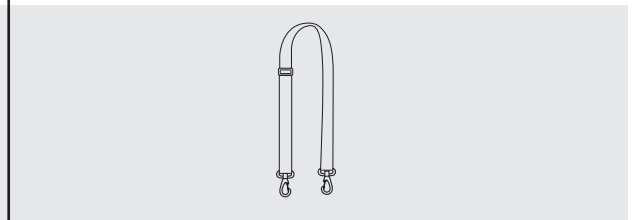

DUST-AWAY™ HARD FLOOR ATTACHMENT & CLEANING PADS INSTRUCTIONS

MICROFIBRE PAD

- 1 Slip two of the tabs between the suction nozzle and the duster base and attach them to the front fasteners on the base. Then pull the other two tabs tightly around to the back fasteners on the base. For best results, ensure that the pad is flat against the bottom surface and secured tightl .
- 2 Use the Dust-Away™ to clean dry bare floor surfaces. Do not use to clean damp floors or wet/sticky messes. Only use pads provided by Sha ®, which are designed to work with the Dust-Away™ attachment.
- 3 Wash the pads separately with warm water either in the washing machine or by hand using liquid detergent.

Do not use bleach or fabric softeners as they may damage or leave a coating that will reduce the cleaning performance of the pads.

Tumble dry low or line dry to extend the life of the microfibre fabric

For best floor cleaning results, we recommend replacing your microfibre pads every 3-4 months following normal us

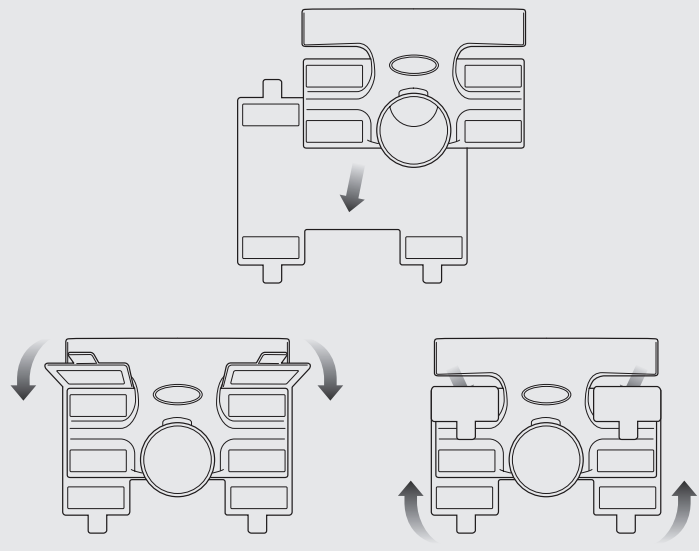
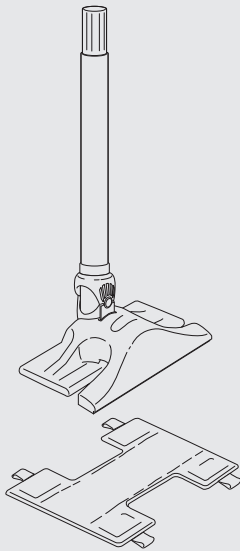

HELPFUL TIPS

SUCTION CONTROL

- 1 This unit is equipped with a suction control collar to help with push and pull on high pile carpets, area rugs and to release suction when dusting delicate objects or drapery. Located at base of top handle, rotate the collar 90° to minimise suction. Be sure to close again for maximum suction.

POWER BUTTONS

- 2 The POWER button turns on suction only. This is ideal for use on bare floors, delicate area rugs and for use with accessories
- 3 The BRUSHROLL button spins the floor brush, ideal for use on carpeted surfaces. Note: The floor brush will only spin once the vacuum is reclined back.

CORD HOOKS

- 4 For quick cord access, rotate upper hook 180° and remove cord. Rotate it back for cord storage.

HEADLIGHTS

- 5 Designed to illuminate debris in dark areas, the headlights illuminate any time the power is on. The headlights are long-lasting and designed to last the life of the vacuum.

HEIGHT ADJUSTMENT

- 6 This floor nozzle has been optimised to work on all types of carpets as well as bare floors so there is never any need to adjust heights for different surfaces.

FILTERS

- 7 Remember to clean your filters regularly under normal use. Also, for optimal performance, tap clean filters between washes as needed.

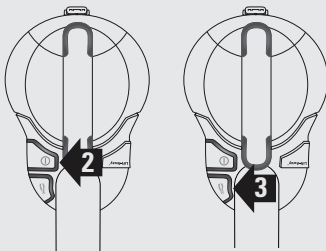
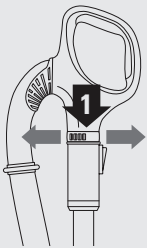

MAINTENANCE

EMPTY THE DUST CUP

- 1 Pull up on the dust cup release latch and lift the dustcup off the pod.
- 2 Holding the dust cup over a garbage bag or can, press the bottom empty release latch.
- 3 Press the top dust cup release latch to access the dust screen and remove built-up debris as required. Turn the dust cup over and empty the upper chamber by holding it by the handle on the side of the dust cup.

CLEAN THE FILTERS

See cleaning schedule on page 2

- 4 With the dust cup removed, remove and rinse the foam and felt filters every 3 months. Let air dry completely before replacing. Tap loose dirt off filters between washes as needed.
- 5 Once a year open the filter grill and remove and rinse the HEPA filter. Let air dry completely before replacing. Hand wash only.

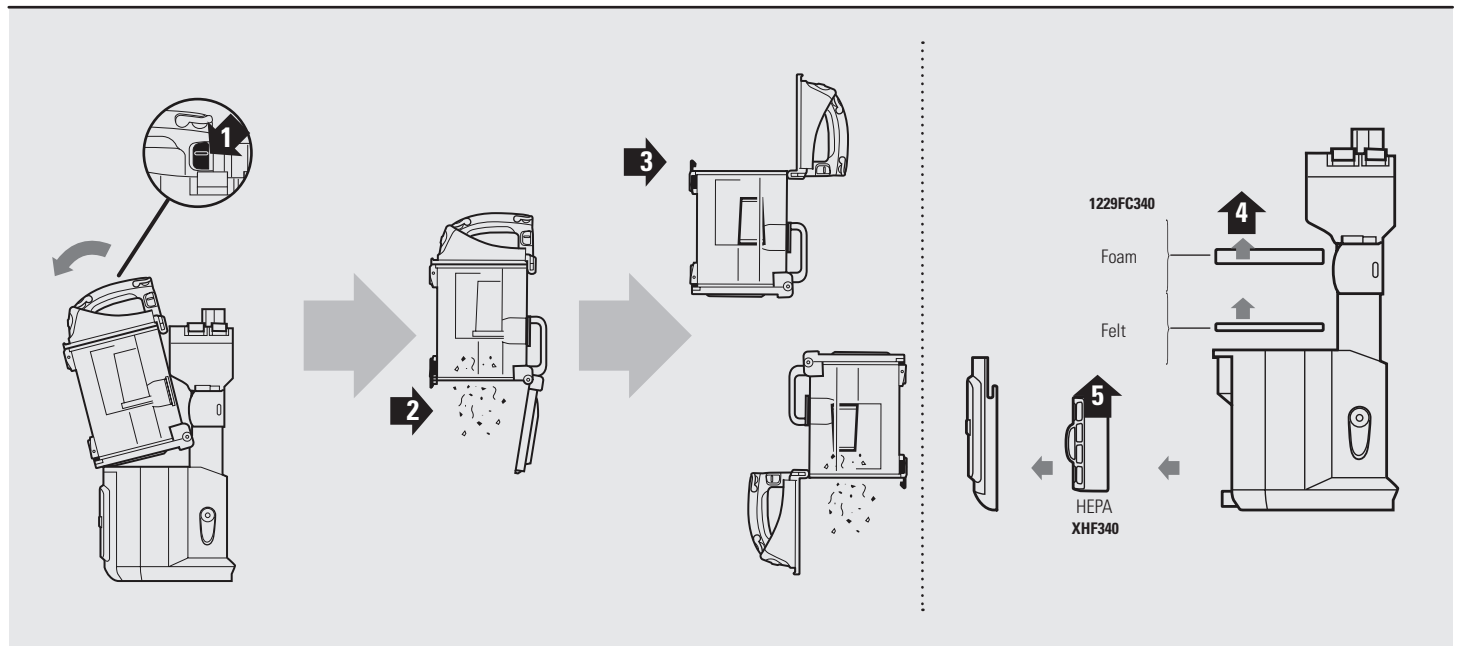

MAINTENANCE

CHECK FOR BLOCKAGES

REMOVE AND INSPECT:

1 HOSE AND TUBES

Remove floor nozzle and extension wand and shine a flashlight up from the bottom to check for possible blockage. Remove dustcup and hose to check intake opening and hose elbow.

2 BOTTOM OF FLOOR NOZZLE

- a Using a coin, turn the locking screws to the unlock position and pull up to expose the airway. Remove any obstructions, close and relock.
- b Remove any string, carpet fibers or hair that may be wrapped around the brushroll

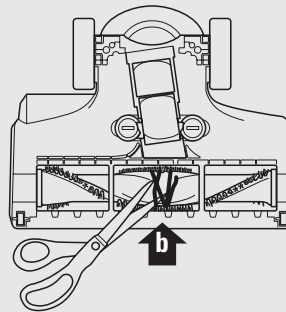
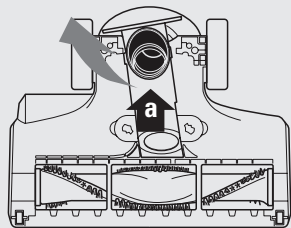
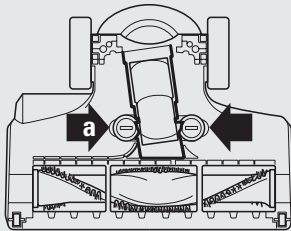

TROUBLE- SHOOTING GUIDE

Vacuum is not picking up dirt. No suction or light suction

- Check filters to see if they need cleaning. Follow instructions for rinsing and drying the filters before re-inserting back into the vacuum.
- Dust cup may be full; empty dust cup.
- Check hose, hose connections, nozzles and accessories for blockages; clear blockages if required.
- Close the suction release on the handle to increase suction power.

Vacuum lifts area rugs

- Suction is powerful. Take care when vacuuming area rugs or rugs with delicately sewn edges. Open the suction release on the handle to decrease suction power.
- Turn off the unit to disengage the brush roll and restart with the POWER button for suction only cleaning.

Brush roll does not spin

- Pull the handle toward you and release the floor nozzle to disengage the auto-off feature
- Turn the unit on by pressing the BRUSHROLL button.
- Immediately turn off and unplug vacuum, disconnect the nozzle and remove blockage before reconnecting and turning vacuum back on.

Vacuum turns off on its own

- This vacuum cleaner is equipped with a motor protective thermostat. If for some reason your vacuum overheats, the thermostat will automatically turn the unit off. Should this occur, perform the following steps to restart the motor thermostat:
 1. Turn the unit off.
 2. Unplug the vacuum.
 3. Empty the dust cup and clean filters.
 4. Check for blockages in hose, accessories and inlet openings.
 5. Allow the unit to cool for a minimum of 45 minutes.
 6. Plug in the vacuum.
 7. Restart the unit using either the POWER or POWER + BRUSHROLL buttons.

WARRANTY TERMS AND CONDITIONS

When a consumer buys a product in the UK, they get the benefit of legal rights relating to the quality of the product (your “statutory rights”). You can enforce these rights against your retailer. However, at Shark we are so confident about the quality of our products that we give you an additional manufacturer’s warranty of up to five years. These terms and conditions relate to our manufacturer’s warranty only – your statutory rights are unaffected.

The conditions below describe the prerequisites and scope of our warranty. They do not affect your statutory rights or the obligations of your retailer and your contract with them.

Shark® Guarantees

A household appliance like a vacuum cleaner constitutes a sizeable investment. Your new machine needs to work properly for as long as possible. The guarantee it comes with is an important consideration - and reflects how much confidence the manufacturer has in its product and manufacturing quality.

Every Shark® machine comes with a free parts and labour guarantee. Our customer service helpline (**0800 862 0453**) is open from 9.00am to 6.00pm Monday - Friday. It’s free to call, and you’ll be put straight through to a Shark representative. You’ll also find online support at www.sharkclean.eu/uk.

How do I register my extended Shark® guarantee?

You can register your guarantee online within 28 days of purchase. To save time, you’ll need the following information about your machine:

- Serial number (on the machine rating label)
- Date you purchased the machine (receipt or delivery note)
- To register online, please visit www.sharkclean.eu/uk/register-guarantee

IMPORTANT

- Both the 12 months and the extended 4 years guarantee will only cover your product from the date of purchase.
- Please keep your receipt at all times. Should you need to use your extended guarantee we will need your receipt to verify the information you have supplied to us is correct. The inability to produce a valid receipt may invalidate your guarantee.

What are the benefits of registering my free Shark® guarantee?

When you register your guarantee we’ll have your details to hand if we ever need to get in touch. You can also receive tips and advice on how to get the best out of your Shark® vacuum and hear the latest news about new Shark® technology and launches.

If you register your guarantee online, you’ll get instant confirmation that we’ve received your details.

How long are new Shark® machines guaranteed for?

Our confidence in our design and quality control means that your new Shark® vacuum cleaner is guaranteed for a total of five years. (12 months plus an extended warranty of 4 years)

What is covered by the free Shark® guarantee?

Repair or replacement of your Shark® machine (at Shark®’s discretion), including all parts and labour. A Shark® guarantee is in addition to your legal rights as a consumer.

What is not covered by the free Shark® guarantee?

- Blockages – For details of how to unblock your vacuum cleaner, please refer to the Operating Manual.
- Normal wear and tear such as brush bar, fuse, belt, batteries etc.
- Accidental damage, faults caused by negligent use or care, misuse, neglect, careless operation or handling of the vacuum cleaner which is not in accordance with the Shark® Operating Manual supplied with your machine.
- Use of the vacuum cleaner for anything other than normal domestic household purposes.
- Use of parts not assembled or installed in accordance with the operating instructions.
- Use of parts and accessories which are not Shark® Genuine Components.
- Faulty installation (except where installed by Shark®).
- Repairs or alterations carried out by parties other than Shark or its agents.

What happens when my guarantee runs out?

Shark® does not design products to last for a limited time. We do appreciate that there may be a desire for our customers to want to repair their vacuum cleaners after the warranty has elapsed. In this case please contact our free phone customer service help line and ask about our out warranty program, on **0800 862 0453**.

Where can I buy genuine Shark® spares and accessories?

Shark® spares and accessories are developed by the same engineers who developed your Shark® vacuum. You’ll find a full range of Shark® spares and replacement parts for all Shark® machines at www.sharkclean.eu/uk/parts. Accessories are at www.sharkclean.eu/uk/accessories.

Please remember that using non-Shark® spares invalidates your guarantee.

Shark®



Euro-Pro Europe Limited
Century Way
Thorpe Park
Leeds
LS15 8ZB
Freephone 0800 862 0453
www.sharkclean.eu

