

# ***Shark***<sup>®</sup>

**Shark DuoClean<sup>®</sup>**  
Corded Vacuum  
with Flexology<sup>™</sup>

**HV390UK**

**Series**

---

**INSTRUCTIONS**



sharkclean.eu





0800 862 0453

# THANK YOU

for purchasing the Shark DuoClean® Corded Vacuum with Flexology™



## REGISTER YOUR PURCHASE

-  registryourshark.com
-  0800 862 0453
-  Scan QR code using mobile device



**TIP:** You can find the model and serial numbers on the QR code label which is located on the handheld vacuum.

## THIS BOOK COVERS MODEL NUMBERS:

HV390UK  
HV390UKT  
HV390UKCO  
HV390QUKT

## RECORD THIS INFORMATION

Model Number: \_\_\_\_\_

Serial Number: \_\_\_\_\_

Date of Purchase (Keep receipt): \_\_\_\_\_

Store of Purchase: \_\_\_\_\_

## TECHNICAL SPECIFICATIONS

Voltage: 220-240V~, 50-60Hz

Watts: 450W

## PLEASE READ CAREFULLY AND KEEP FOR FUTURE REFERENCE.

This instruction manual is designed to help you get a complete understanding of your new Shark DuoClean® Corded Vacuum with Flexology™

If you have any questions, please call the Customer Service line on 0800 862 0453

# CONTENTS

|   |           |
|---|-----------|
| <b>Important Safety Instructions</b> .....                                      | <b>3</b>  |
| <b>Getting To Know Your Shark DuoClean® Corded Vacuum with Flexology™</b> ..... | <b>5</b>  |
| <b>Assembling Your Vacuum</b> .....   | <b>7</b>  |
| <b>Using the Motorised Floor Nozzle</b> .....                                   | <b>8</b>  |
| <b>Using Your Vacuum in Above-Floor Mode</b> .....                              | <b>9</b>  |
| <b>Accessories</b> .....  | <b>11</b> |
| <b>Storage</b> .....  | <b>12</b> |
| <b>Maintaining Your Vacuum</b> .....  | <b>13</b> |
| Emptying the Dust Cup .....   | 13        |
| Cleaning the Filters .....  | 14        |
| Maintaining the Brushroll .....   | 15        |
| Maintaining the Soft Roller .....   | 16        |
| Checking for Blockages .....  | 16        |
| <b>Troubleshooting Guide</b> .....  | <b>17</b> |
| <b>Warranty</b> .....   | <b>18</b> |

# IMPORTANT SAFETY INSTRUCTIONS

FOR HOUSEHOLD USE ONLY • PLEASE READ ALL INSTRUCTIONS BEFORE USING THIS VACUUM.

## ⚠ WARNING

**REDUCE THE RISK OF FIRE, ELECTRIC SHOCK, INJURY, OR PROPERTY DAMAGE:**

### GENERAL WARNINGS

- 1 Your vacuum cleaner may consist of a motorized nozzle, wand, hose, and/or vacuum pod. This device contains electrical connections, electrical wiring, and moving parts that potentially present risk to the user.
- 2 Use only identical replacement parts.
- 3 Carefully observe and follow the instructions provided below to avoid improper use of the appliance. **DO NOT** use the vacuum for any purpose other than those described in this manual.
- 4 Before use, carefully inspect all parts for any damage. **DO NOT** use if any parts are damaged.
- 5 The use of an extension cord is **NOT** recommended.
- 6 **CAUTION:** This vacuum cleaner handle contains electrical connections. This vacuum contains no serviceable parts.

### USE WARNINGS

- 7 This appliance can be used by persons with reduced physical, sensory or mental capabilities or lack of experience and knowledge if they have been given supervision or instruction concerning use of the appliance in a safe way and understand the hazards involved. Cleaning and user maintenance shall not be made by children. Keep the appliance and its cord out of reach of children. Do not allow the appliance to be used by children. Do not allow to be used as a toy. Close supervision is necessary when used near children.
- 8 Always turn off the vacuum cleaner before connecting or disconnecting any motorized nozzles or other accessories.
- 9 **DO NOT** handle plug or vacuum cleaner with wet hands.

- 10 **DO NOT** use without filters in place.
- 11 Only use Shark® branded filters and accessories. Failure to do so will also void the warranty.
- 12 **DO NOT** damage the power cord:
  - a) **DO NOT** pull or carry vacuum cleaner by the cord or use the cord as a handle.
  - b) **DO NOT** unplug by pulling on cord. Grasp the plug, not the cord.
  - c) **DO NOT** run the vacuum cleaner over the power cord, close a door on the cord, pull the cord around sharp corners, or leave the cord near heated surfaces.
- 13 **DO NOT** put any objects into nozzle or accessory openings. **DO NOT** use with any opening blocked; keep free of dust, lint, hair, and anything that may reduce airflow.
- 14 **DO NOT** use if nozzle or accessory airflow is restricted. If the air paths or the motorized floor nozzle become blocked, turn the vacuum cleaner off and unplug from electrical outlet. Remove all obstructions before you plug in and turn on the unit again.
- 15 Keep nozzle and all vacuum openings away from hair, face, fingers, uncovered feet, or loose clothing.
- 16 **DO NOT** use if vacuum cleaner is not working as it should, or has been dropped, damaged, left outdoors, or dropped into water.
- 17 If the supply cord is damaged, it must be replaced by the manufacturer, its service agent or similar qualified persons in order to avoid a hazard.
- 18 Use extra care when cleaning on stairs.
- 19 **DO NOT** leave the vacuum cleaner unattended while plugged in.

# SAVE THESE INSTRUCTIONS

READ ALL INSTRUCTIONS BEFORE USE

- 20 When powered on, keep the vacuum cleaner moving over the carpet surface at all times to avoid damaging the carpet fibres.
- 21 **DO NOT** place vacuum cleaner on unstable surfaces such as chairs or tables.
- 22 Your Shark® vacuum may not be designed to stand up on its own. When taking a break from cleaning, you may need to lean it against furniture or a wall, or lay it flat on the floor. Using the vacuum for an application where the unit lacks stability may result in personal injury.
- 23 **DO NOT** use to pick up:
  - a) Liquids
  - b) Large objects
  - c) Hard or sharp objects (glass, nails, screws, or coins)
  - d) Large quantities of dust (drywall dust, fireplace ash, or embers). **DO NOT** use as an attachment to power tools for dust collection.
  - e) Smoking or burning objects (hot coals, cigarette butts, or matches)
  - f) Flammable or combustible materials (lighter fluid, gasoline, or kerosene)
  - g) Toxic materials (chlorine bleach, ammonia, or drain cleaner)
- 24 **DO NOT** use in the following areas:
  - a) Poorly lit areas
  - b) Wet or damp surfaces
  - c) Outdoor areas
  - d) Spaces that are enclosed and may contain explosive or toxic fumes or vapors (lighter fluid, gasoline, kerosene, paint, paint thinners, mothproofing substances, or flammable dust)
- 25 Turn off all controls before plugging in or unplugging the vacuum.
- 26 Unplug from electrical outlet when not in use and before any maintenance or cleaning.
- 27 Hand wash with water only. Washing with cleaning chemicals could damage the unit.
- 28 During cleaning or routine maintenance, **DO NOT** cut anything other than hair, fibres, or string wrapped around the brushroll.
- 29 Allow all filters to air-dry completely before replacing in the vacuum to prevent liquid from being drawn into electric parts.
- 30 Make sure the dust cup and all filters are in place after routine maintenance.
- 31 If provided, secure the power cord around the two cord hooks during storage.

# GETTING TO KNOW YOUR Shark DuoClean® Corded Vacuum with Flexology™

## WELCOME!

Congratulations on your purchase. Use this instruction manual to learn about your new vacuum's great features. From assembly to use to maintenance, you will find it all in here.

### MAIN UNIT

- A** Power/Selector Switch
- B** Handheld Vacuum
- C** Dust Cup Release
- D** Dust Cup Empty Button
- E** Flexology™ Wand Release
- F** Flexology™ Storage Carry Handle
- G** Flexology™ Lock Release Button
- H** Upper Cord Wrap Hook
- I** Flexology™ Wand
- J** Lower Wand Release Pedal
- K** Motorised Floor Nozzle
- L** Lower Cord Wrap Hook
- M** Brushroll Garage Release Buttons
- N** Headlights

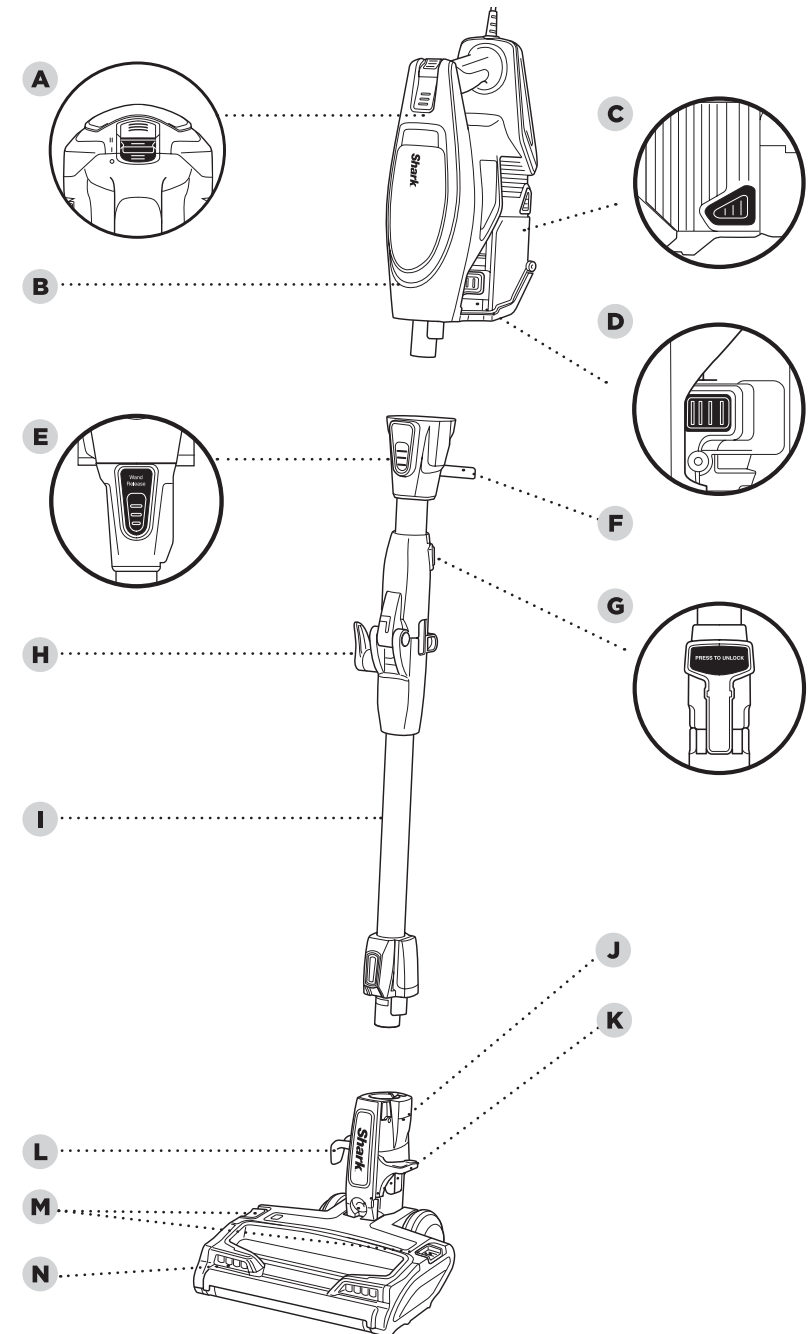

## ASSEMBLING YOUR VACUUM

**⚠ WARNING:** This vacuum does not stand up on its own. Using the unit when it lacks stability may result in personal injury. To place in Flexology™ Storage mode, press the Flexology™ Lock Release Button and gently fold the handheld vacuum forward toward the floor nozzle.

**NOTE:** Before vacuuming your delicate area rugs or carpet, refer to the manufacturer's recommended cleaning instructions.

### WHAT DOES THE BRUSHROLL INDICATOR LIGHT MEAN?

#### Solid Green

The brushrolls are on and working as they should.

#### Solid Red

There is a jam in the brushroll area. Turn your vacuum off and remove the blockage.

#### No Light

The brushrolls are not spinning.

### DID YOU KNOW?

The motorised floor nozzle has LED headlights that illuminate the floor surface being cleaned. The lights turn on automatically in either speed setting.

### STEP 1

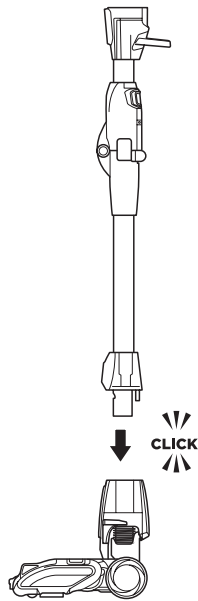

- 1 Insert the wand into the motorised floor nozzle connector, pressing it in until it clicks securely into place.

### STEP 2

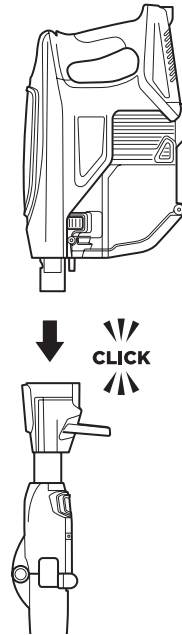

- 2 Insert the handheld vacuum into the top of the wand, pressing it in until it clicks securely into place.

## USING THE MOTORISED FLOOR NOZZLE

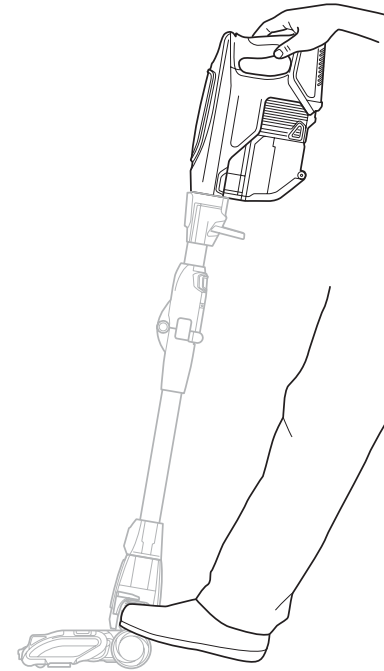

- 1 Slide the Power/Selector Switch to one of the 3 settings:

**Setting 0:** Turns off power.

**Setting I:** For cleaning hard floors and rugs.

**Setting II:** For cleaning thick pile carpets.

To start cleaning, recline wand to activate brushrolls.

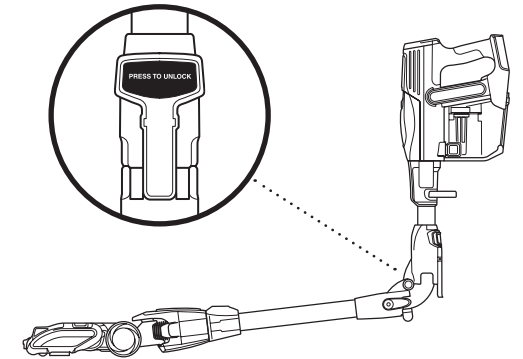

### USING THE MULTIFLEX™ WAND

To easily access hard-to-reach areas under furniture, press the Flexology™ Lock Release Button to position the wand to a lower angle.

## USING YOUR VACUUM IN ABOVE-FLOOR MODE

**NOTE:** Both power settings provide the same suction power.

**TIP:** You can attach the handheld vacuum directly to the motorised floor nozzle for convenient stair cleaning.

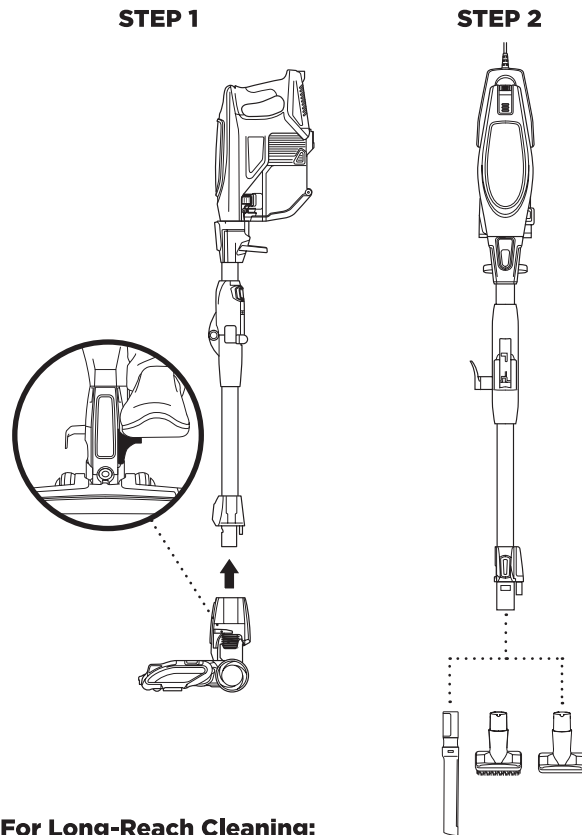

### For Long-Reach Cleaning:

- 1** Stand the vacuum upright. Step on the foot pedal and pull the wand up to disconnect it from the motorised floor nozzle.
- 2** Attach desired cleaning accessory to the wand. Press Flexology™ button to vacuum with wand at an angle.

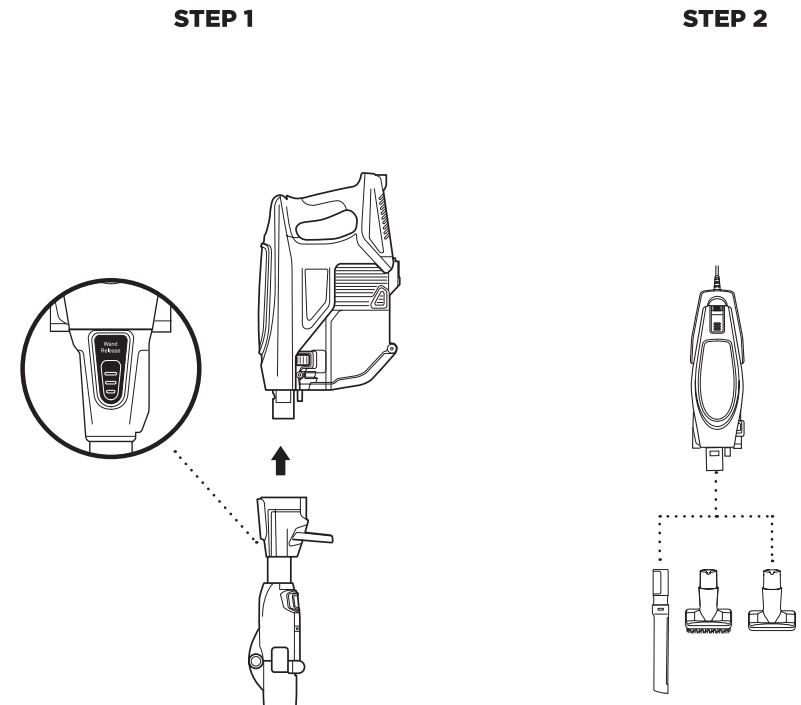

### For Short-Reach Cleaning:

- 1** Press the Wand Release button on the top of the wand to disconnect it from the handheld vacuum.
- 2** Attach desired cleaning accessory or motorised floor nozzle to the handheld vacuum.

## ACCESSORIES

There are a variety of accessories that are compatible with this vacuum series.

The lid of the box shows the select accessories that are included with your model.

To purchase additional accessories, visit [sharkaccessories.eu](http://sharkaccessories.eu)

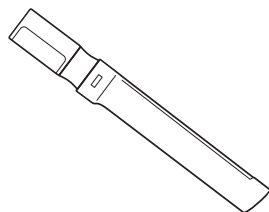

### A Crevice Tool

Clean tight spaces or reach skirting boards and ceilings with this slim crevice tool.

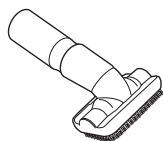

### B Dusting Brush

Great for dusting a multitude of surfaces such as shelves, skirting boards, window frames, and more.



### C Upholstery Tool

Perfect for large-particle pickup, dusting, and removing pet hair and lint from furniture and other upholstered surfaces.

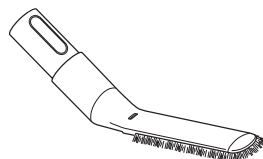

### D Anti-Allergen Dust Brush

Nylon fibre bristles specially designed for removing fine dust and allergen particles from the most delicate surfaces.

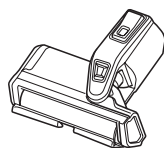

### E Deep-Cleaning Motorised Pet Tool

Motorised compact brush powerful enough to remove deeply embedded allergens, dirt, and hair from multiple surfaces.

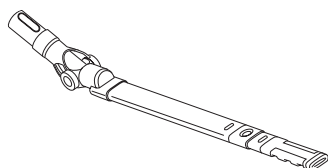

### F Under Appliance Wand

Pivoting wand that extends to clean under appliances and on top of furniture.

## STORAGE

 **TIP:** The carry handle located below the handheld vacuum can also be used to assist in taking the vacuum in and out of Flexology™ Storage mode.

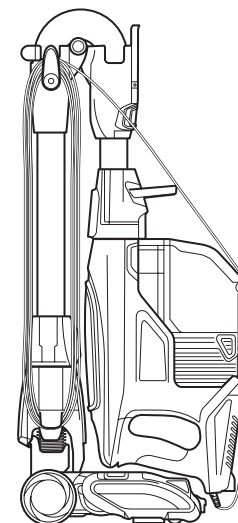

- 1 Looking at the vacuum from the side with the cord hooks, wrap the power cord anti-clockwise around the hooks, starting under the bottom hook. Then press the Flexology™ Wand Lock Release button and gently fold the handheld vacuum forward toward the floor nozzle. Use the handle to carry the vacuum to its storage location.

To take the vacuum out of storage mode, press the Flexology™ Wand Lock Release button while lifting up the handheld vacuum. When straightened, the wand will lock in place.

# MAINTAINING YOUR VACUUM

**⚠ WARNING:** To reduce the risk of shock and unintended operation, turn off power and unplug unit before servicing.

**⚠ WARNING:** Hand wash filters only with water to prevent damage from cleaning chemicals. Allow ALL filters to air-dry completely before replacing them in the vacuum to prevent liquid from being drawn into electric parts.

**★ IMPORTANT:** Clean the dust screen inside the dust cup as required.

**NOTE:** Empty dust cup when debris reaches the MAX fill line.

## RECOMMENDED FILTER CLEANING SCHEDULE:

### Pre-Motor Filter Kit

(Foam & Felt)  
Clean once a month.

### Post-Motor Filter

Clean every 9 months.

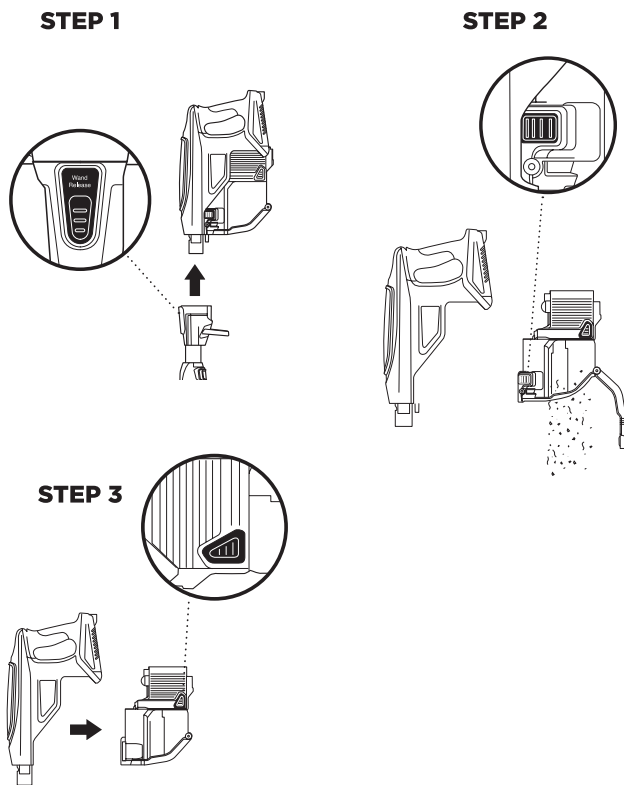

## EMPTYING THE DUST CUP

- 1 Disconnect the handheld vacuum by pressing the Wand Release button on the top of the wand.
- 2 To remove the dust cup from the handheld vacuum, squeeze the two Dust Cup Release buttons on either side of the base then pull out.
- 3 Hold dust cup over a bin and press the Empty button on the front of the dust cup. Close the bottom lid and insert dust cup back into handheld vacuum, pressing it until it clicks.

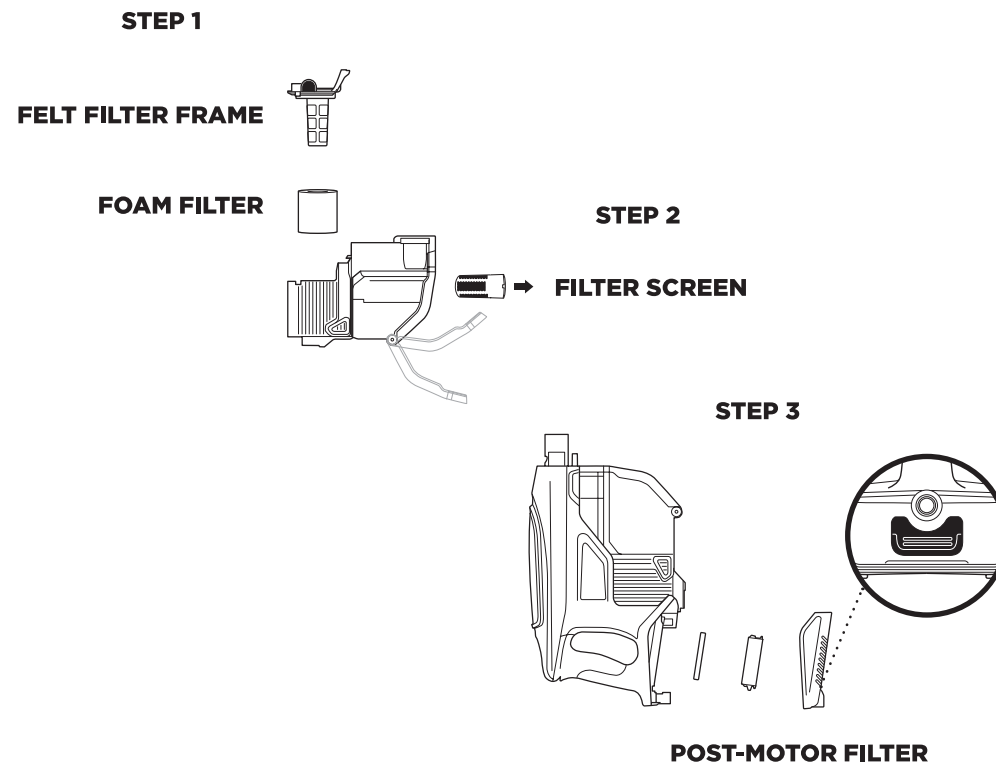

## CLEANING THE FILTERS

- 1 Access the pre-motor filter by removing the dust cup from the vacuum. Separate foam filter from felt filter frame and rinse them with water. **DO NOT** use soap. Tap loose dirt off filters as needed. Allow filters to air-dry completely, then reinsert them and reattach the dust cup to the vacuum.
- 2 Press the Empty button to open the door then pull the screen to remove from dust cup. Remove any hair or debris that may be wrapped around it and tap off dirt as needed. To replace push firmly back in place.
- 3 Access the Post-Motor filter under the handle. Remove the filter and rinse it with water. **DO NOT** use soap.



## MAINTAINING YOUR VACUUM - CONT.

**⚠ WARNING:** To reduce the risk of shock and unintended operation, turn off power and unplug unit before servicing.

**⚠ WARNING:** When cleaning brushroll, be sure to not cut anything other than hair, string, fibres, or other debris.

**💡 TIP:** If nozzle headlights are flashing, then the brushroll garage is not completely closed. Ensure the garage is completely closed by pressing down firmly on both sides.

**NOTE:** Heavy usage over time may require minimal upkeep to maintain your vacuum's appearance.

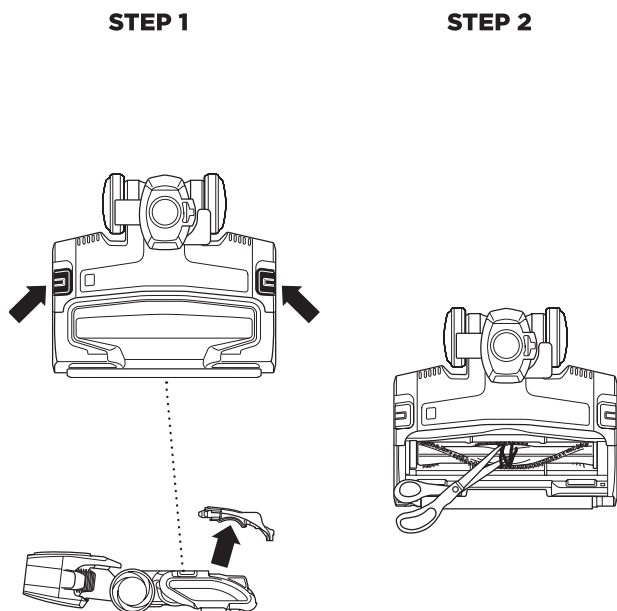

### MAINTAINING THE BRUSHROLL

- 1 Open the brushroll lid by sliding both release buttons away from you, toward the back of the nozzle, then lifting off the lid. Remove any string, hair, or debris that may be wrapped around the brushroll by running scissors along the guide on the brushroll.
- 2 Press down on both sides of the lid until it clicks into place.

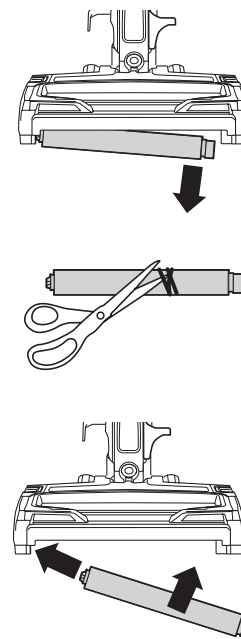

### MAINTAINING THE SOFT ROLLER

- 1 Open the brushroll by sliding both release buttons away from you, toward the back of the nozzle, then lifting off the lid. Lift out the Soft Roller by the tab on the right side. Clean off any string, carpet fibres, or hair that may be wrapped around the Soft Roller. Remove debris from the roller housing.
- 2 Wash the Soft Roller as needed, using only water. Air-dry completely for at least 24 hours before returning it to the brushroll garage.
- 3 Reinsert the Soft Roller by sliding it into the front of the nozzle until it clicks into place. Close the brushroll garage by inserting the tabs on the lid into the slots, then pressing down on both sides of the lid until it clicks into place.

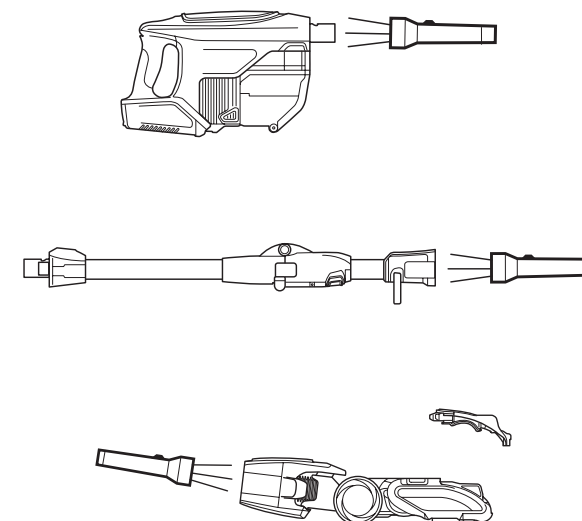

### CHECKING FOR BLOCKAGES: HANDHELD, WAND, AND FLOOR NOZZLE

- 1 Remove the wand from the handheld vacuum and check all intake openings on the dust cup.
- 2 Remove the floor nozzle from the wand and check the wand for blockages.
- 3 Tilt neck of floor nozzle back to straighten the airway, then remove blockages.

## TROUBLESHOOTING GUIDE

**⚠ WARNING: To reduce the risk of shock and unintended operation, turn off power and unplug unit before servicing.**

**Vacuum is not picking up debris. No suction or light suction.**  
(Refer to Maintenance section for more information.)

- Check filters to see if they need cleaning. Follow instructions for rinsing and completely air-drying the filters before reinserting into the vacuum.
- Dust cup may be full; empty dust cup.
- Check floor nozzle for blockages; clear blockages if required.
- Remove any string, carpet fibres, or hair that may be wrapped around the brushroll and Soft Roller or trapped behind the Soft Roller.

**Vacuum lifts area rugs.**

- Suction is powerful. Take care when vacuuming area rugs or rugs with delicately sewn edges.
- Turn off the unit to disengage the brushroll and restart with the Power/Selector slider switch.

**Brushroll/Soft Roller does not spin.**

- If Brushroll Indicator Light on the floor nozzle turns red, the brushroll and/or Soft Roller have stopped spinning. Immediately turn off and unplug vacuum and remove blockage before reconnecting and turning vacuum back on.
- If Brushroll Indicator Light on the floor nozzle is green, the blockage has been successfully cleared. If the light is still red, please contact Customer Service on 0800 862 0453.
- If nozzle LED headlights are flashing, this means the brushroll garage is not completely closed. Turn off and unplug the vacuum. Ensure the brushroll garage is closed by inserting the tabs on the lid into the slots, then pressing down on both sides of the lid until it clicks into place.

**Vacuum turns off on its own.**

This vacuum is equipped with a motor-protective thermostat so the vacuum will shut off if it overheats. Should this occur, perform the following steps to restart the motor-protective thermostat:

1. Turn off vacuum and unplug it.
2. Empty dust cup and clean filters (see Maintenance section).
3. Check for blockages in hose, accessories, and inlet openings.
4. Allow unit to cool for a minimum of 45 minutes.
5. Plug in vacuum and turn it on.

Note: If vacuum still does not start, contact Customer Service on 0800 862 0453.

## Shark® WARRANTY TERMS AND CONDITIONS

When a consumer buys a product in the UK, they get the benefit of legal rights relating to the quality of the product (your "statutory rights"). You can enforce these rights against your retailer. However, at Shark we are so confident about the quality of our products that we give you an additional manufacturer's warranty of up to five years upon registration with Shark. Offer valid only in United Kingdom and Republic of Ireland. These terms and conditions relate to our manufacturer's warranty only – your statutory rights are unaffected. The conditions below describe the prerequisites and scope of our warranty. They do not affect your statutory rights or the obligations of your retailer and your contract with them.

### Shark® Guarantees

A household appliance like a vacuum cleaner constitutes a sizeable investment. Your new machine needs to work properly for as long as possible. The guarantee it comes with is an important consideration - and reflects how much confidence the manufacturer has in its product and manufacturing quality. Every Shark machine comes with a free parts and labour guarantee. Our customer service helpline (0800 862 0453) is open from 9.00am to 6.00pm Monday - Friday. It's free to call, and you'll be put straight through to a Shark representative. You'll also find online support at [sharkclean.eu/uk](http://sharkclean.eu/uk).

### How do I register my Shark guarantee?

You can register your guarantee online within 28 days of purchase. To save time, you'll need the following information about your machine:

- Serial number (on the machine rating label).
- Date you purchased the machine (receipt or delivery note).
- To register online, please visit [sharkclean.eu/uk/register-guarantee](http://sharkclean.eu/uk/register-guarantee).

### IMPORTANT

- Both the 12 months and the extended 4 years guarantee will only cover your product from the date of purchase.
- Please keep your receipt at all times. Should you need to use your extended guarantee we will need your receipt to verify the information you have supplied to us is correct. The inability to produce a valid receipt may invalidate your guarantee.

### What are the benefits of registering my free Shark guarantee?

When you register your guarantee we'll have your details to hand if we ever need to get in touch. You can also receive tips and advice on how to get the best out of your Shark vacuum and hear the latest news about new Shark® technology and launches. If you register your guarantee online, you'll get instant confirmation that we've received your details.

### How long are new Shark machines guaranteed for?

Our confidence in our design and quality control means that your new Shark vacuum cleaner is guaranteed for a total of five years. (12 months plus an extended warranty of 4 years).

### What is covered by the free Shark guarantee?

Repair or replacement of your Shark machine (at Shark's discretion), including all parts and labour. A Shark guarantee is in addition to your legal rights as a consumer.

What is not covered by the free Shark guarantee?

- Blockages – For details of how to unblock your vacuum cleaner, please refer to the Operating Manual.
- Normal wear and tear such as brush bar, fuse, belt, batteries etc.
- Accidental damage, faults caused by negligent use or care, misuse, neglect, careless operation or handling of the vacuum cleaner which is not in accordance with the Shark Operating Manual supplied with your machine.
- Use of the vacuum cleaner for anything other than normal domestic household purposes.
- Use of parts not assembled or installed in accordance with the operating instructions.
- Use of parts and accessories which are not Shark Genuine Components.
- Faulty installation (except where installed by Shark).
- Repairs or alterations carried out by parties other than Shark or its agents.

### What happens when my guarantee runs out?

Shark does not design products to last for a limited time. We do appreciate that there may be a desire for our customers to want to repair their vacuum cleaners after the warranty has elapsed. In this case please contact our free phone customer service help line and ask about our out warranty program, on 0800 862 0453.

### Where can I buy genuine Shark spares and accessories?

Shark spares and accessories are developed by the same engineers who developed your Shark vacuum. You'll find a full range of Shark spares and replacement parts for all Shark machines at [sharkclean.eu/uk/parts](http://sharkclean.eu/uk/parts). Accessories are at [sharkclean.eu/uk/accessories](http://sharkclean.eu/uk/accessories).

Please remember that using non-Shark spares invalidates your guarantee.



This appliance complies with the WEEE-Directive 2012/19/EU on the disposal of electrical and electronic equipment (WEEE).



This marking indicates that this product should not responsibly to promote the sustainable reuse of material sources. To return your used device, please use the return and collection systems or contact the retailer where this product was purchased. They can take this product for environmental safe recycling.

■ This appliance complies with the European directives for electromagnetic compatibility (EMC) 2014/30/EU and its revisions, as well as Low Voltage Directive (LVD) 2014/35/EU and its revisions.

**Euro-Pro Europe Limited,  
3150 Century Way,  
Thorpe Park,  
Leeds,  
LS15 8ZB, UK  
+44 (0)800 862 0453  
www.sharkclean.eu**

Illustrations may differ from actual product. We are constantly striving to improve our products; therefore the specifications contained herein are subject to change without notice.

SHARK DUOCLEAN are registered trademarks of SharkNinja Operating LLC.

Flexology™ is a trademark of SharkNinja Operating LLC.

© 2019 SharkNinja Operating LLC  
SN00042\_HV390UK\_Series\_IB\_REV\_191113\_AW1  
PRINTED IN CHINA

 **@sharkcleaninguk**

 **@sharkcleanuk**

 **@sharkcleanuk**